



Republic of the Philippines
Department of Transportation
CIVIL AVIATION AUTHORITY OF THE PHILIPPINES
AREA CENTER I
Laoag International Airport

REHABILITATION OF BUILDINGS AT DARAYDAY FACILITY

Sixth Edition

TABLE OF CONTENTS

<u>SECTION I. INVITATION TO BID</u>	5
<u>SECTION II. INSTRUCTIONS TO BIDDERS</u>	7
<u>1. Scope of Bid</u>	8
<u>2. Funding Information</u>	8
<u>3. Bidding Requirements</u>	8
<u>4. Corrupt, Fraudulent, Collusive, Coercive, and Obstructive Practices</u>	8
<u>5. Eligible Bidders</u>	9
<u>6. Origin of Associated Goods</u>	9
<u>7. Subcontracts</u>	9
<u>8. Pre-Bid Conference</u>	10
<u>9. Clarification and Amendment of Bidding Documents</u>	10
<u>10. Documents Comprising the Bid: Eligibility and Technical Components</u>	10
<u>11. Documents Comprising the Bid: Financial Component</u>	11
<u>12. Alternative Bids</u>	11
<u>13. Bid Prices</u>	11
<u>14. Bid and Payment Currencies</u>	11
<u>15. Bid Security</u>	12
<u>16. Sealing and Marking of Bids</u>	12
<u>17. Deadline for Submission of Bids</u>	12
<u>18. Opening and Preliminary Examination of Bids</u>	12
<u>19. Detailed Evaluation and Comparison of Bids</u>	12
<u>20. Post Qualification</u>	13
<u>21. Signing of the Contract</u>	13
<u>SECTION III. BID DATA SHEET</u>	14
<u>SECTION IV. GENERAL CONDITIONS OF CONTRACT</u>	17
<u>1. Scope of Contract</u>	18
<u>2. Sectional Completion of Works</u>	18
<u>3. Possession of Site</u>	18
<u>4. The Contractor’s Obligations</u>	18
<u>5. Performance Security</u>	19
<u>6. Site Investigation Reports</u>	19
<u>7. Warranty</u>	19

<u>8.</u>	<u>Liability of the Contractor</u>	19
<u>9.</u>	<u>Termination for Other Causes</u>	19
<u>10.</u>	<u>Dayworks</u>	20
<u>11.</u>	<u>Program of Work</u>	20
<u>12.</u>	<u>Instructions, Inspections and Audits</u>	20
<u>13.</u>	<u>Advance Payment</u>	20
<u>14.</u>	<u>Progress Payments</u>	20
<u>15.</u>	<u>Operating and Maintenance Manuals</u>	21
<u>SECTION V. SPECIAL CONDITIONS OF CONTRACT</u>		22
<u>SECTION VI. SPECIFICATIONS</u>		25
<u>SECTION VII. DRAWINGS</u>		30
<u>SECTION VIII. BILL OF QUANTITIES</u>		43
<u>SECTION IX. CHECKLIST OF TECHNICAL AND FINANCIAL DOCUMENTS</u>		48

Section I. Invitation to Bid

Notes on the Invitation to Bid

The Invitation to Bid (IB) provides information that enables potential Bidders to decide whether to participate in the procurement at hand. The IB shall be posted in accordance with Section 21.2 of the 2016 revised IRR of RA No. 9184.

Apart from the essential items listed in the Bidding Documents, the IB should also indicate the following:

- a. The date of availability of the Bidding Documents, which shall be from the time the IB is first advertised/posted until the deadline for the submission and receipt of bids;
- b. The place where the Bidding Documents may be acquired or the website where it may be downloaded;
- c. The deadline for the submission and receipt of bids; and
- d. Any important bid evaluation criteria.

The IB should be incorporated into the Bidding Documents. The information contained in the IB must conform to the Bidding Documents and in particular to the relevant information in the Bid Data Sheet.

CIVIL AVIATION AUTHORITY OF THE PHILIPPINES

LAOAG INTERNATIONAL AIRPORT

Invitation to Bid for *Rehabilitation of Buildings at Darayday Facility*

1. The **Civil Aviation Authority of the Philippines, Area Center I** through the **Annual Procurement Plan, FY 2023** intends to apply the sum of *One Million Seven Hundred Ninety-Nine Thousand Seven Hundred Forty-Three Pesos and Eighty-Three Centavos (Php1,799,743.83)* being the Approved Budget for the Contract (ABC) to payments under the contract for *Rehabilitation of Buildings at Darayday Facility, to wit:*

Lot No.	Description	Qty.	Total ABC	Bid Security/Bid Securing Declaration OR Cashier's/Manager's Check Equivalent to at least 2% of ABC	Surety Bond Equivalent to at least 5% of ABC
1	Rehabilitation of Buildings at Darayday Facility	1 Lot	1,799,743.83	35,994.88	89,987.19

Bids received in excess of the ABC shall be automatically rejected at bid opening.

2. The **Civil Aviation Authority of the Philippines, Area Center I** now invites bids for the above Procurement Project. Completion of the Works is required *Seventy (70) Calendar Days*. Bidders should have completed a contract similar to the Project. The description of an eligible bidder is contained in the Bidding Documents, particularly, in Section II (Instructions to Bidders).
3. Bidding will be conducted through open competitive bidding procedures using non-discretionary "*pass/fail*" criterion as specified in the 2016 revised Implementing Rules and Regulations (IRR) of Republic Act (RA) No. 9184.
4. Interested bidders may obtain further information from **Civil Aviation Authority of the Philippines, Area Center I** and inspect the Bidding Documents at the address given below from *8AM-5PM, Monday-Friday*.

5. A complete set of Bidding Documents may be acquired by interested bidders on **September 26, 2023** from given address and website/s *below and upon payment of the applicable fee for the Bidding Documents, pursuant to the latest Guidelines issued by the GPPB, in the amount of Five Thousand Six Hundred Pesos Only (Php 5,600.00)*. The Procuring Entity shall allow the bidder to present its proof of payment for the fees **by in person or through the given email address below**.
6. The **Civil Aviation Authority of the Philippines, Area Center I** will hold a Pre-Bid Conference on **October 4, 2023 9:00 AM** at the **Bids and Awards Committee Conference Room, Concession Building, Laoag International Airport** and/or through video conferencing/webcasting via **Google Meet/Zoom**, which shall be open to prospective bidders.
7. Bids must be duly received by the BAC Secretariat through manual submission at the office address as indicated below on or before **October 17, 2023 at 9:00 AM**. Late bids shall not be accepted.
8. All bids must be accompanied by a bid security in any of the acceptable forms and in the amount stated in **ITB** Clause 16.
9. Bid opening shall be on **October 17, 2023 at 9:00 AM** at **Bids and Awards Committee Conference Room, Concession Building, Laoag International Airport** and/or through **Google Meet/Zoom**. Bids will be opened in the presence of the bidders' representatives who choose to attend the activity.
10. The **Civil Aviation Authority of the Philippines, Area Center I** reserves the right to reject any and all bids, declare a failure of bidding, or not award the contract at any time prior to contract award in accordance with Sections 35.6 and 41 of the 2016 revised Implementing Rules and Regulations (IRR) of RA No. 9184, without thereby incurring any liability to the affected bidder or bidders.
11. For further information, please refer to:

HAZELLE MAY C. ANDRES

Head, BAC Secretariat

Laoag International Airport, Brgy. Araniw, Laoag City

(077) 670-8446 telefax

laoag.bac@gmail.com / areacenter1_bac@caap.gov.ph

12. You may visit the following websites:

For downloading of Bidding Documents:

(Original Signed)
ATTY. RIZZA JOY VALLESTERO
BAC Chairman

Section II. Instructions to Bidders

Notes on the Instructions to Bidders

This Section on the Instruction to Bidders (ITB) provides the information necessary for bidders to prepare responsive bids, in accordance with the requirements of the Procuring Entity. It also provides information on bid submission, eligibility check, opening and evaluation of bids, post-qualification, and on the award of contract.

1. Scope of Bid

The Procuring Entity, **Civil Aviation Authority of the Philippines, Area Center I** invites Bids for the *Rehabilitation of Buildings at Darayday Facility*, with Project Identification Number **BAC-2023-041**.

The Procurement Project (referred to herein as “Project”) is for the construction of Works, as described in Section VI (Specifications).

2. Funding Information

2.1. The GOP through the source of funding as indicated below for **Annual Procurement Plan, CY 2023** in the amount of *One Million Seven Hundred Ninety-Nine Thousand Seven Hundred Forty-Three Pesos and Eighty-Three Centavos (Php1,799,743.83)*.

2.2. The source of funding is GOCC and GFIs, the Corporate Operating Budget.

3. Bidding Requirements

The Bidding for the Project shall be governed by all the provisions of RA No. 9184 and its 2016 revised IRR, including its Generic Procurement Manual and associated policies, rules and regulations as the primary source thereof, while the herein clauses shall serve as the secondary source thereof.

Any amendments made to the IRR and other GPPB issuances shall be applicable only to the ongoing posting, advertisement, or invitation to bid by the BAC through the issuance of a supplemental or bid bulletin.

The Bidder, by the act of submitting its Bid, shall be deemed to have inspected the site, determined the general characteristics of the contracted Works and the conditions for this Project, such as the location and the nature of the work; (b) climatic conditions; (c) transportation facilities; (c) nature and condition of the terrain, geological conditions at the site communication facilities, requirements, location and availability of construction aggregates and other materials, labor, water, electric power and access roads; and (d) other factors that may affect the cost, duration and execution or implementation of the contract, project, or work and examine all instructions, forms, terms, and project requirements in the Bidding Documents.

4. Corrupt, Fraudulent, Collusive, Coercive, and Obstructive Practices

The Procuring Entity, as well as the Bidders and Contractors, shall observe the highest standard of ethics during the procurement and execution of the contract. They or through an agent shall not engage in corrupt, fraudulent, collusive, coercive, and obstructive practices defined under Annex “I” of the 2016 revised IRR of RA No. 9184 or other integrity violations in competing for the Project.

5. Eligible Bidders

- 5.1. Only Bids of Bidders found to be legally, technically, and financially capable will be evaluated.
- 5.2. The Bidder must have an experience of having completed a Single Largest Completed Contract (SLCC) that is similar to this Project, equivalent to at least fifty percent (50%) of the ABC adjusted, if necessary, by the Bidder to current prices using the PSA's CPI, except under conditions provided for in Section 23.4.2.4 of the 2016 revised IRR of RA No. 9184.

A contract is considered to be "similar" to the contract to be bid if it has the major categories of work stated in the **BDS**.
- 5.3. For Foreign-funded Procurement, the Procuring Entity and the foreign government/foreign or international financing institution may agree on another track record requirement, as specified in the Bidding Document prepared for this purpose.
- 5.4. The Bidders shall comply with the eligibility criteria under Section 23.4.2 of the 2016 IRR of RA No. 9184.

6. Origin of Associated Goods

There is no restriction on the origin of Goods other than those prohibited by a decision of the UN Security Council taken under Chapter VII of the Charter of the UN.

7. Subcontracts

- 7.1. The Bidder may subcontract portions of the Project to the extent allowed by the Procuring Entity as stated herein, but in no case more than fifty percent (50%) of the Project.

The Procuring Entity has prescribed that:

- a. Subcontracting is not allowed.
- 7.1. *[If Procuring Entity has determined that subcontracting is allowed during the bidding, state:]* The Bidder must submit together with its Bid the documentary requirements of the subcontractor(s) complying with the eligibility criteria stated in **ITB** Clause 5 in accordance with Section 23.4 of the 2016 revised IRR of RA No. 9184 pursuant to Section 23.1 thereof.
 - 7.2. *[If subcontracting is allowed during the contract implementation stage, state:]* The Supplier may identify its subcontractor during the contract implementation stage. Subcontractors identified during the bidding may be changed during the implementation of this Contract. Subcontractors must submit the documentary requirements under Section 23.1 of the 2016 revised IRR of RA No. 9184 and comply with the eligibility criteria specified in **ITB** Clause 5 to the implementing or end-user unit.

- 7.3. Subcontracting of any portion of the Project does not relieve the Contractor of any liability or obligation under the Contract. The Supplier will be responsible for the acts, defaults, and negligence of any subcontractor, its agents, servants, or workmen as fully as if these were the Contractor's own acts, defaults, or negligence, or those of its agents, servants, or workmen.

8. Pre-Bid Conference

The Procuring Entity will hold a pre-bid conference for this Project on the specified date and time and either at its physical address and/or through videoconferencing/webcasting} as indicated in paragraph 6 of the **IB**.

9. Clarification and Amendment of Bidding Documents

Prospective bidders may request for clarification on and/or interpretation of any part of the Bidding Documents. Such requests must be in writing and received by the Procuring Entity, either at its given address or through electronic mail indicated in the **IB**, at least ten (10) calendar days before the deadline set for the submission and receipt of Bids.

10. Documents Comprising the Bid: Eligibility and Technical Components

- 10.1. The first envelope shall contain the eligibility and technical documents of the Bid as specified in **Section IX. Checklist of Technical and Financial Documents**.
- 10.2. If the eligibility requirements or statements, the bids, and all other documents for submission to the BAC are in foreign language other than English, it must be accompanied by a translation in English, which shall be authenticated by the appropriate Philippine foreign service establishment, post, or the equivalent office having jurisdiction over the foreign bidder's affairs in the Philippines. For Contracting Parties to the Apostille Convention, only the translated documents shall be authenticated through an apostille pursuant to GPPB Resolution No. 13-2019 dated 23 May 2019. The English translation shall govern, for purposes of interpretation of the bid.
- 10.3. A valid PCAB License is required, and in case of joint ventures, a valid special PCAB License, and registration for the type and cost of the contract for this Project. Any additional type of Contractor license or permit shall be indicated in the **BDS**.
- 10.4. A List of Contractor's key personnel (e.g., Project Manager, Project Engineers, Materials Engineers, and Foremen) assigned to the contract to be bid, with their complete qualification and experience data shall be provided. These key personnel must meet the required minimum years of experience set in the **BDS**.
- 10.5. A List of Contractor's major equipment units, which are owned, leased, and/or under purchase agreements, supported by proof of ownership, certification of

availability of equipment from the equipment lessor/vendor for the duration of the project, as the case may be, must meet the minimum requirements for the contract set in the **BDS**.

11. Documents Comprising the Bid: Financial Component

- 11.1. The second bid envelope shall contain the financial documents for the Bid as specified in **Section IX. Checklist of Technical and Financial Documents**.
- 11.2. Any bid exceeding the ABC indicated in paragraph 1 of the **IB** shall not be accepted.
- 11.3. For Foreign-funded procurement, a ceiling may be applied to bid prices provided the conditions are met under Section 31.2 of the 2016 revised IRR of RA No. 9184.

12. Alternative Bids

Bidders shall submit offers that comply with the requirements of the Bidding Documents, including the basic technical design as indicated in the drawings and specifications. Unless there is a value engineering clause in the **BDS**, alternative Bids shall not be accepted.

13. Bid Prices

All bid prices for the given scope of work in the Project as awarded shall be considered as fixed prices, and therefore not subject to price escalation during contract implementation, except under extraordinary circumstances as determined by the NEDA and approved by the GPPB pursuant to the revised Guidelines for Contract Price Escalation guidelines.

14. Bid and Payment Currencies

- 14.1. Bid prices may be quoted in the local currency or tradeable currency accepted by the BSP at the discretion of the Bidder. However, for purposes of bid evaluation, Bids denominated in foreign currencies shall be converted to Philippine currency based on the exchange rate as published in the BSP reference rate bulletin on the day of the bid opening.
- 14.2. *Payment of the contract price shall be made in:*
 - a. Philippine Pesos.

15. Bid Security

- 15.1. The Bidder shall submit a Bid Securing Declaration or any form of Bid Security in the amount indicated in the **BDS**, which shall be not less than the percentage of the ABC in accordance with the schedule in the **BDS**.
- 15.2. The Bid and bid security shall be valid until *or for One Hundred Twenty Days (120 days) from the date of the opening of bids*. Any bid not accompanied by an acceptable bid security shall be rejected by the Procuring Entity as non-responsive.

16. Sealing and Marking of Bids

Each Bidder shall submit one copy of the first and second components of its Bid.

The Procuring Entity may request additional hard copies and/or electronic copies of the Bid. However, failure of the Bidders to comply with the said request shall not be a ground for disqualification.

If the Procuring Entity allows the submission of bids through online submission to the given website or any other electronic means, the Bidder shall submit an electronic copy of its Bid, which must be digitally signed. An electronic copy that cannot be opened or is corrupted shall be considered non-responsive and, thus, automatically disqualified.

17. Deadline for Submission of Bids

The Bidders shall submit on the specified date and time and either at its physical address or through online submission as indicated in paragraph 7 of the **IB**.

18. Opening and Preliminary Examination of Bids

- 18.1. The BAC shall open the Bids in public at the time, on the date, and at the place specified in paragraph 9 of the **IB**. The Bidders' representatives who are present shall sign a register evidencing their attendance. In case videoconferencing, webcasting or other similar technologies will be used, attendance of participants shall likewise be recorded by the BAC Secretariat.

In case the Bids cannot be opened as scheduled due to justifiable reasons, the rescheduling requirements under Section 29 of the 2016 revised IRR of RA No. 9184 shall prevail.

- 18.2. The preliminary examination of Bids shall be governed by Section 30 of the 2016 revised IRR of RA No. 9184.

19. Detailed Evaluation and Comparison of Bids

- 19.1. The Procuring Entity's BAC shall immediately conduct a detailed evaluation of all Bids rated "*passed*" using non-discretionary pass/fail criteria. The BAC

shall consider the conditions in the evaluation of Bids under Section 32.2 of 2016 revised IRR of RA No. 9184.

- 19.2. If the Project allows partial bids, all Bids and combinations of Bids as indicated in the **BDS** shall be received by the same deadline and opened and evaluated simultaneously so as to determine the Bid or combination of Bids offering the lowest calculated cost to the Procuring Entity. Bid Security as required by **ITB** Clause 15 shall be submitted for each contract (lot) separately.
- 19.3. In all cases, the NFCC computation pursuant to Section 23.4.2.6 of the 2016 revised IRR of RA No. 9184 must be sufficient for the total of the ABCs for all the lots participated in by the prospective Bidder.

20. Post Qualification

Within a non-extendible period of five (5) calendar days from receipt by the Bidder of the notice from the BAC that it submitted the Lowest Calculated Bid, the Bidder shall submit its latest income and business tax returns filed and paid through the BIR Electronic Filing and Payment System (eFPS), and other appropriate licenses and permits required by law and stated in the **BDS**.

21. Signing of the Contract

The documents required in Section 37.2 of the 2016 revised IRR of RA No. 9184 shall form part of the Contract. Additional Contract documents are indicated in the **BDS**.

Section III. Bid Data Sheet

Notes on the Bid Data Sheet (BDS)

The Bid Data Sheet (BDS) consists of provisions that supplement, amend, or specify in detail, information, or requirements included in the ITB found in Section II, which are specific to each procurement.

This Section is intended to assist the Procuring Entity in providing the specific information in relation to corresponding clauses in the ITB and has to be prepared for each specific procurement.

The Procuring Entity should specify in the BDS information and requirements specific to the circumstances of the Procuring Entity, the processing of the procurement, and the bid evaluation criteria that will apply to the Bids. In preparing the BDS, the following aspects should be checked:

- a. Information that specifies and complements provisions of the ITB must be incorporated.
- b. Amendments and/or supplements, if any, to provisions of the ITB as necessitated by the circumstances of the specific procurement, must also be incorporated.

Bid Data Sheet

ITB Clause																									
5.2	For this purpose, contracts similar to the Project refer to contracts which have the same major categories of work, which shall be: <ol style="list-style-type: none"> a. <i>Rehabilitation of Buildings at Darayday Facility</i> b. The bidder's SLCC similar to the contract to the bid should be have been completed within the last five (5) years prior to the deadline for the submission and receipt of bids. 																								
7.1	<i>No subcontracting allowed</i>																								
10.3	<i>No further instruction</i>																								
10.4	The key personnel must meet the required minimum years of experience set below: <table border="1" style="width: 100%; border-collapse: collapse;"> <thead> <tr> <th style="text-align: left;"><u>Key Personnel</u></th> <th style="text-align: center;"><u>General Experience</u></th> <th style="text-align: center;"><u>Relevant Experience</u></th> </tr> </thead> <tbody> <tr> <td>Electrician</td> <td style="text-align: center;">1 year</td> <td style="text-align: center;">1 year</td> </tr> <tr> <td>Crane and flat-bed truck Operator/Driver</td> <td style="text-align: center;">1 year</td> <td style="text-align: center;">1 year</td> </tr> </tbody> </table>	<u>Key Personnel</u>	<u>General Experience</u>	<u>Relevant Experience</u>	Electrician	1 year	1 year	Crane and flat-bed truck Operator/Driver	1 year	1 year															
<u>Key Personnel</u>	<u>General Experience</u>	<u>Relevant Experience</u>																							
Electrician	1 year	1 year																							
Crane and flat-bed truck Operator/Driver	1 year	1 year																							
10.5	The minimum major equipment requirements are the following: <table border="1" style="width: 100%; border-collapse: collapse;"> <thead> <tr> <th style="text-align: left;"><u>Equipment</u></th> <th style="text-align: center;"><u>Capacity</u></th> <th style="text-align: center;"><u>Number of Units</u></th> </tr> </thead> <tbody> <tr> <td>Flat Bed Truck</td> <td style="text-align: center;">12 meters/6 tons</td> <td style="text-align: center;">1</td> </tr> <tr> <td>Mobile Crane</td> <td style="text-align: center;">6 tons</td> <td style="text-align: center;">1</td> </tr> <tr> <td>Cut-off Machine</td> <td></td> <td></td> </tr> <tr> <td>Welding Machine</td> <td></td> <td></td> </tr> <tr> <td>Angle Grinder</td> <td></td> <td></td> </tr> <tr> <td>Electric Drill</td> <td></td> <td></td> </tr> <tr> <td>PPR Fusion Machine</td> <td></td> <td></td> </tr> </tbody> </table>	<u>Equipment</u>	<u>Capacity</u>	<u>Number of Units</u>	Flat Bed Truck	12 meters/6 tons	1	Mobile Crane	6 tons	1	Cut-off Machine			Welding Machine			Angle Grinder			Electric Drill			PPR Fusion Machine		
<u>Equipment</u>	<u>Capacity</u>	<u>Number of Units</u>																							
Flat Bed Truck	12 meters/6 tons	1																							
Mobile Crane	6 tons	1																							
Cut-off Machine																									
Welding Machine																									
Angle Grinder																									
Electric Drill																									
PPR Fusion Machine																									
12	<i>No Further Instruction</i>																								
15.1	The bid security shall be in the form of a Bid Securing Declaration or any of the following forms and amounts: <ol style="list-style-type: none"> a. The amount of not less than Thirty-Five Thousand Nine Hundred Ninety-four Pesos and Eighty-Eight Centavos only (Php 35,994.88), if bid security is in cash, cashier's/manager's check, bank draft/guarantee or irrevocable letter of credit; b. The amount of not less than Eighty-Nine Thousand Nine Hundred Eighty-Seven Pesos and Nineteen Centavos only (Php 89,987.19) if bid security is in Surety Bond. 																								
19.2	<i>Partial bid is NOT ALLOWED</i>																								
20	<i>No further instruction</i>																								
21	Additional contract documents relevant to the Project that may be required by existing laws and/or the Procuring Entity, such as construction schedule and S-curve, manpower schedule, construction methods, equipment utilization schedule, construction safety and health program approved by the DOLE, and other acceptable tools of project scheduling.																								

A). Pursuant to procurement principle under the Government Procurement Reform Act (RA No. 9184) and as per memorandum given by the Director General, state that, all prospective bidders shall henceforth be required to submit the following additional documents such as;

1. A certification, under oath, attesting that they have no pending case(s) against the Government, in addition to the eligibility requirements for bidders as prescribed under the 2016 Revised Implementing Rules and Regulations (R-IRR) of RA No. 9184.

2. Legal Clearance to be issued by the CAAP Enforcement and Legal Service with respect to the non-pendency of any cases of prospective bidders against this Authority.

NOTE: These documents are being required during the post-qualification stage of the procurement process.

Section IV. General Conditions of Contract

Notes on the General Conditions of Contract

The General Conditions of Contract (GCC) in this Section, read in conjunction with the Special Conditions of Contract in Section V and other documents listed therein, should be a complete document expressing all the rights and obligations of the parties.

Matters governing performance of the Contractor, payments under the contract, or matters affecting the risks, rights, and obligations of the parties under the contract are included in the GCC and Special Conditions of Contract.

Any complementary information, which may be needed, shall be introduced only through the Special Conditions of Contract.

1. Scope of Contract

This Contract shall include all such items, although not specifically mentioned, that can be reasonably inferred as being required for its completion as if such items were expressly mentioned herein. All the provisions of RA No. 9184 and its 2016 revised IRR, including the Generic Procurement Manual, and associated issuances, constitute the primary source for the terms and conditions of the Contract, and thus, applicable in contract implementation. Herein clauses shall serve as the secondary source for the terms and conditions of the Contract.

This is without prejudice to Sections 74.1 and 74.2 of the 2016 revised IRR of RA No. 9184 allowing the GPPB to amend the IRR, which shall be applied to all procurement activities, the advertisement, posting, or invitation of which were issued after the effectivity of the said amendment.

2. Sectional Completion of Works

If sectional completion is specified in the **Special Conditions of Contract (SCC)**, references in the Conditions of Contract to the Works, the Completion Date, and the Intended Completion Date shall apply to any Section of the Works (other than references to the Completion Date and Intended Completion Date for the whole of the Works).

3. Possession of Site

3.1 The Procuring Entity shall give possession of all or parts of the Site to the Contractor based on the schedule of delivery indicated in the **SCC**, which corresponds to the execution of the Works. If the Contractor suffers delay or incurs cost from failure on the part of the Procuring Entity to give possession in accordance with the terms of this clause, the Procuring Entity's Representative shall give the Contractor a Contract Time Extension and certify such sum as fair to cover the cost incurred, which sum shall be paid by Procuring Entity.

3.2 If possession of a portion is not given by the above date, the Procuring Entity will be deemed to have delayed the start of the relevant activities. The resulting adjustments in contract time to address such delay may be addressed through contract extension provided under Annex "E" of the 2016 revised IRR of RA No. 9184.

4. The Contractor's Obligations

The Contractor shall employ the key personnel named in the Schedule of Key Personnel indicating their designation, in accordance with **ITB** Clause 10.3 and specified in the **BDS**, to carry out the supervision of the Works.

The Procuring Entity will approve any proposed replacement of key personnel only if their relevant qualifications and abilities are equal to or better than those of the personnel listed in the Schedule.

5. Performance Security

- 5.1. Within ten (10) calendar days from receipt of the Notice of Award from the Procuring Entity but in no case later than the signing of the contract by both parties, the successful Bidder shall furnish the performance security in any of the forms prescribed in Section 39 of the 2016 revised IRR.
- 5.2. The Contractor, by entering into the Contract with the Procuring Entity, acknowledges the right of the Procuring Entity to institute action pursuant to RA No. 3688 against any subcontractor be they an individual, firm, partnership, corporation, or association supplying the Contractor with labor, materials and/or equipment for the performance of this Contract.

6. Site Investigation Reports

The Contractor, in preparing the Bid, shall rely on any Site Investigation Reports referred to in the **SCC** supplemented by any information obtained by the Contractor.

7. Warranty

- 7.1. In case the Contractor fails to undertake the repair works under Section 62.2.2 of the 2016 revised IRR, the Procuring Entity shall forfeit its performance security, subject its property(ies) to attachment or garnishment proceedings, and perpetually disqualify it from participating in any public bidding. All payables of the GOP in his favor shall be offset to recover the costs.
- 7.2. The warranty against Structural Defects/Failures, except that occasioned-on force majeure, shall cover the period from the date of issuance of the Certificate of Final Acceptance by the Procuring Entity. Specific duration of the warranty is found in the **SCC**.

8. Liability of the Contractor

Subject to additional provisions, if any, set forth in the **SCC**, the Contractor's liability under this Contract shall be as provided by the laws of the Republic of the Philippines.

If the Contractor is a joint venture, all partners to the joint venture shall be jointly and severally liable to the Procuring Entity.

9. Termination for Other Causes

Contract termination shall be initiated in case it is determined *prima facie* by the Procuring Entity that the Contractor has engaged, before, or during the implementation of the contract, in unlawful deeds and behaviors relative to contract acquisition and implementation, such as, but not limited to corrupt, fraudulent, collusive, coercive, and obstructive practices as stated in **ITB** Clause 4.

10. Dayworks

Subject to the guidelines on Variation Order in Annex “E” of the 2016 revised IRR of RA No. 9184, and if applicable as indicated in the **SCC**, the Dayworks rates in the Contractor’s Bid shall be used for small additional amounts of work only when the Procuring Entity’s Representative has given written instructions in advance for additional work to be paid for in that way.

11. Program of Work

11.1. The Contractor shall submit to the Procuring Entity’s Representative for approval the said Program of Work showing the general methods, arrangements, order, and timing for all the activities in the Works. The submissions of the Program of Work are indicated in the **SCC**.

11.2. The Contractor shall submit to the Procuring Entity’s Representative for approval an updated Program of Work at intervals no longer than the period stated in the **SCC**. If the Contractor does not submit an updated Program of Work within this period, the Procuring Entity’s Representative may withhold the amount stated in the **SCC** from the next payment certificate and continue to withhold this amount until the next payment after the date on which the overdue Program of Work has been submitted.

12. Instructions, Inspections and Audits

The Contractor shall permit the GOP or the Procuring Entity to inspect the Contractor’s accounts and records relating to the performance of the Contractor and to have them audited by auditors of the GOP or the Procuring Entity, as may be required.

13. Advance Payment

The Procuring Entity shall, upon a written request of the Contractor which shall be submitted as a Contract document, make an advance payment to the Contractor in an amount not exceeding fifteen percent (15%) of the total contract price, to be made in lump sum, or at the most two installments according to a schedule specified in the **SCC**, subject to the requirements in Annex “E” of the 2016 revised IRR of RA No. 9184.

14. Progress Payments

The Contractor may submit a request for payment for Work accomplished. Such requests for payment shall be verified and certified by the Procuring Entity’s Representative/Project Engineer. Except as otherwise stipulated in the **SCC**, materials and equipment delivered on the site but not completely put in place shall not be included for payment.

15. Operating and Maintenance Manuals

- 15.1. If required, the Contractor will provide “as built” Drawings and/or operating and maintenance manuals as specified in the **SCC**.
- 15.2. If the Contractor does not provide the Drawings and/or manuals by the dates stated above, or they do not receive the Procuring Entity’s Representative’s approval, the Procuring Entity’s Representative may withhold the amount stated in the **SCC** from payments due to the Contractor.

Section V. Special Conditions of Contract

Notes on the Special Conditions of Contract

Similar to the BDS, the clauses in this Section are intended to assist the Procuring Entity in providing contract-specific information in relation to corresponding clauses in the GCC found in Section IV.

The Special Conditions of Contract (SCC) complement the GCC, specifying contractual requirements linked to the special circumstances of the Procuring Entity, the Procuring Entity's country, the sector, and the Works procured. In preparing this Section, the following aspects should be checked:

- a. Information that complements provisions of the GCC must be incorporated.
- b. Amendments and/or supplements to provisions of the GCC as necessitated by the circumstances of the specific purchase, must also be incorporated.

However, no special condition which defeats or negates the general intent and purpose of the provisions of the GCC should be incorporated herein.

Special Conditions of Contract

GCC Clause	
2	<i>No further instruction</i>
4.1	<p><i>[Specify the schedule of delivery of the possession of the site to the Contractor, whether full or in part.]</i></p> <p>The Intended Completion Date is Seventy (70) calendar days.</p> <p>NOTE: The contract duration shall be reckoned from the start date and not from contract effectivity date.</p>
6	The site investigation reports are: <i>[list here the required site investigation reports.]</i>
7.2	<p><i>[Select one, delete the other.]</i></p> <p><i>[In case of permanent structures, such as buildings of types 4 and 5 as classified under the National Building Code of the Philippines and other structures made of steel, iron, or concrete which comply with relevant structural codes (e.g., DPWH Standard Specifications), such as, but not limited to, steel/concrete bridges, flyovers, aircraft movement areas, ports, dams, tunnels, filtration and treatment plants, sewerage systems, power plants, transmission and communication towers, railway system, and other similar permanent structures:]</i> Fifteen (15) years.</p> <p><i>[In case of semi-permanent structures, such as buildings of types 1, 2, and 3 as classified under the National Building Code of the Philippines, concrete/asphalt roads, concrete river control, drainage, irrigation lined canals, river landing, deep wells, rock causeway, pedestrian overpass, and other similar semi-permanent structures:]</i> Five (5) years.</p> <p><i>[In case of other structures, such as bailey and wooden bridges, shallow wells, spring developments, and other similar structures:]</i> Two (2) years.</p>
10	<p>a. Dayworks are applicable at the rate shown in the Contractor's original Bid.</p>
11.1	The Contractor shall submit the Program of Work to the Procuring Entity's Representative within <i>[insert number]</i> days of delivery of the Notice of Award.
11.2	The amount to be withheld for late submission of an updated Program of Work is <i>[insert amount]</i> .
13	The amount of the advance payment is <i>[insert amount as percentage of the contract price that shall not exceed 15% of the total contract price and schedule of payment]</i> .
14	<i>[If allowed by the Procuring Entity, state:]</i> Materials and equipment delivered on the site but not completely put in place shall be included for payment.

15.1	The date by which operating and maintenance manuals are required is <i>[date]</i> . The date by which “as built” drawings are required is <i>[date]</i> .
15.2	The amount to be withheld for failing to produce “as built” drawings and/or operating and maintenance manuals by the date required is <i>[amount in local currency]</i> .

Section VI. Specifications

Notes on Specifications

A set of precise and clear specifications is a prerequisite for Bidders to respond realistically and competitively to the requirements of the Procuring Entity without qualifying or conditioning their Bids. In the context of international competitive bidding, the specifications must be drafted to permit the widest possible competition and, at the same time, present a clear statement of the required standards of workmanship, materials, and performance of the goods and services to be procured. Only if this is done will the objectives of economy, efficiency, and fairness in procurement be realized, responsiveness of Bids be ensured, and the subsequent task of bid evaluation facilitated. The specifications should require that all goods and materials to be incorporated in the Works be new, unused, of the most recent or current models, and incorporate all recent improvements in design and materials unless provided otherwise in the Contract.

Samples of specifications from previous similar projects are useful in this respect. The use of metric units is mandatory. Most specifications are normally written specially by the Procuring Entity or its representative to suit the Works at hand. There is no standard set of Specifications for universal application in all sectors in all regions, but there are established principles and practices, which are reflected in these PBDs.

There are considerable advantages in standardizing General Specifications for repetitive Works in recognized public sectors, such as highways, ports, railways, urban housing, irrigation, and water supply, in the same country or region where similar conditions prevail. The General Specifications should cover all classes of workmanship, materials, and equipment commonly involved in construction, although not necessarily to be used in a particular Works Contract. Deletions or addenda should then adapt the General Specifications to the particular Works.

Care must be taken in drafting specifications to ensure that they are not restrictive. In the specification of standards for goods, materials, and workmanship, recognized international standards should be used as much as possible. Where other particular standards are used, whether national standards or other standards, the specifications should state that goods, materials, and workmanship that meet other authoritative standards, and which ensure substantially equal or higher quality than the standards mentioned, will also be acceptable. The following clause may be inserted in the SCC.

Sample Clause: Equivalency of Standards and Codes

Wherever reference is made in the Contract to specific standards and codes to be met by the goods and materials to be furnished, and work performed or tested, the provisions of the latest current edition or revision of the relevant standards and codes in effect shall apply, unless otherwise expressly stated in the Contract. Where such standards and codes are national, or relate to a particular country or region, other authoritative standards that ensure

a substantially equal or higher quality than the standards and codes specified will be accepted subject to the Procuring Entity's Representative's prior review and written consent. Differences between the standards specified and the proposed alternative standards shall be fully described in writing by the Contractor and submitted to the Procuring Entity's Representative at least twenty-eight (28) days prior to the date when the Contractor desires the Procuring Entity's Representative's consent. In the event the Procuring Entity's Representative determines that such proposed deviations do not ensure substantially equal or higher quality, the Contractor shall comply with the standards specified in the documents.

These notes are intended only as information for the Procuring Entity or the person drafting the Bidding Documents. They should not be included in the final Bidding Documents.

SCOPE OF WORKS

1.0 GENERAL

-The works to be accomplished by the successful bidders shall consist of furnishing, supervision of labor, materials, supplies, tools and equipment to complete the Scope of Works of the **Rehabilitation of Buildings at Darayday Facility**.

-All Scope of Works must be according to plans and specifications. The quality and types of materials must conform to the specifications and must be approved first by the Engineer In-charge assigned by CAAP-LIA

-The Contractor shall be responsible in providing safety perimeter fence or security fences, personal protective equipment (PPE) for staffs and workers on site while construction is ongoing. Safety reports should be prepared regularly.

-Contractor shall provide accomplishment work pictures (Printed/Soft Copy: before, during and after) for documentation to the Engineer-in-charge assigned by CAAP-LIA.

2.0 LOCATION OF THE PROJECT

-The Contract to be bid is located at Barangay 49-A Darayday Laoag City, a Facility of Laoag International Airport.

3.0 SCOPE OF WORKS

-The details of work are at best enumerated below, but be noted that the Contract includes all works and services although not specifically mentioned herein, but are needed to fully complete the Project.

-The Project covers the supply of labor, materials, mobilization/demobilization, tools/equipment, and construction related permits necessary for **Rehabilitation of Buildings at Darayday Facility** with the following scope of works which shall be done in accordance with the approved plans, specifications and provision of contract to wit: (Work shall include but is not limited to the following)

4.0 CIVIL/STRUCTURAL WORKS

I. HAULING

The work includes all materials, labor, equipment and performance all Painting. The contractor/service provider shall undertake the mobilization and hauling for the three (3) container van. One (1) - 2.5x2.5x12mtrs long container van to be transferred at Staffhouse and two (2) - 2.4x2.5x6mtrs long container van to be transferred at Darayday.

II. CONCRETE WORKS

The work includes all materials, labor, equipment and performance for concrete works. The contractor/service provider shall undertake the pouring of the flooring for the garage area for the Main Building, Construction of the extension of the building 2, construction of concrete pedestal for the three (3) container vans and floor of the space in between the 2-container van as indicated on the plan and for construction of public toilet. (Please see attached Plan and PoW for complete details and specifications).

III. TILE WORKS

The work includes all materials, labor, equipment and performance for tile works. The contractor/service provider shall undertake the laying of tiles for Main Building, Building II, Floor Tiles with pebbles in between the two container vans and Comfort Room (Please see attached Plan and PoW for complete details and specifications).

IV. ROOFING WORKS

The work includes all materials, labor, equipment and performance for roofing works. The contractor/service provider shall undertake the construction fabrication of truss and installation of roofing sheets for the Main Building, Building II, Container Van and Comfort Room (Please see attached Plan and PoW for complete details and specifications).

V. CEILING WORKS

The work includes all materials, labor, equipment and performance for Ceiling works. The contractor/service provider shall undertake the Installation of Ceiling Joist and Ceiling Board/Panel for the Main Building, Building II, Container Van, and Comfort Room. It also includes Painting for the Ceiling Board (Please see attached Plan and PoW for complete details and specifications).

VI. STEEL WORKS

The work includes all materials, labor, equipment and performance for steel works. The contractor/service provider shall undertake the Fabrication of Steel Railing for Building II and steel railing of the two (2) container vans. (Please see attached Plan and PoW for complete details and specifications).

VII. FLOORING WORKS

The work includes all materials, labor, equipment and performance for flooring works. The contractor/service provider shall undertake the laying of flooring joist and flooring board and tiles for the container van only. (Please see attached Plan and PoW for complete details and specifications).

VIII. WALLING WORKS

The work includes all materials, labor, equipment and performance for walling works. The contractor/service provider shall undertake the Installation of Wall Joist and Wall Board for Container Van only. (Please see attached Plan and PoW for complete details and specifications).

IX. ELECTRICAL WORKS

The work includes all materials, labor, equipment and performance for electrical works. The contractor/service provider shall undertake the Laying out the electrical wirings for the Main Building, Building II, Container Van and Comfort Room (Please see attached Plan and PoW for complete details and specifications).

X. PAINTING WORKS

The work includes all materials, labor, equipment and performance for painting works. The contractor/service provider shall undertake the painting of walls and columns for Building II, and for painting of container van (outside only) (Please see attached Plan and PoW for complete details and specifications).

XI. PLUMBING WORKS

The work includes all materials, labor, equipment and performance for plumbing works. The contractor/service provider shall undertake the laying of water and sewer line pipes for the Main Building, Building II and Comfort Room. (Please see attached Plan and PoW for complete details and specifications).

XII. CONSTRUCTION OF SEPTIC TANK

The work includes all materials, labor, equipment and performance for construction of septic tank. The contractor/service provider shall undertake the construction of new Septic Tank in between the Comfort Room and Building II (Please see attached Plan and PoW for complete details and specifications).

XIII. INSTALLATION OF DOORS AND WINDOWS

The work includes all materials, labor, equipment and performance for installation of doors and windows. The contractor/service provider shall undertake the Installation of Doors and Windows (Please see attached Plan and PoW for complete details and specifications).

XIV. OCCUPATIONAL HEALTH AND SAFETY PROGRAM

Every personnel that will be working on the restricted area shall wear necessary Personal Protective Equipment. Safety officer will be present during the Implementation of the Project.



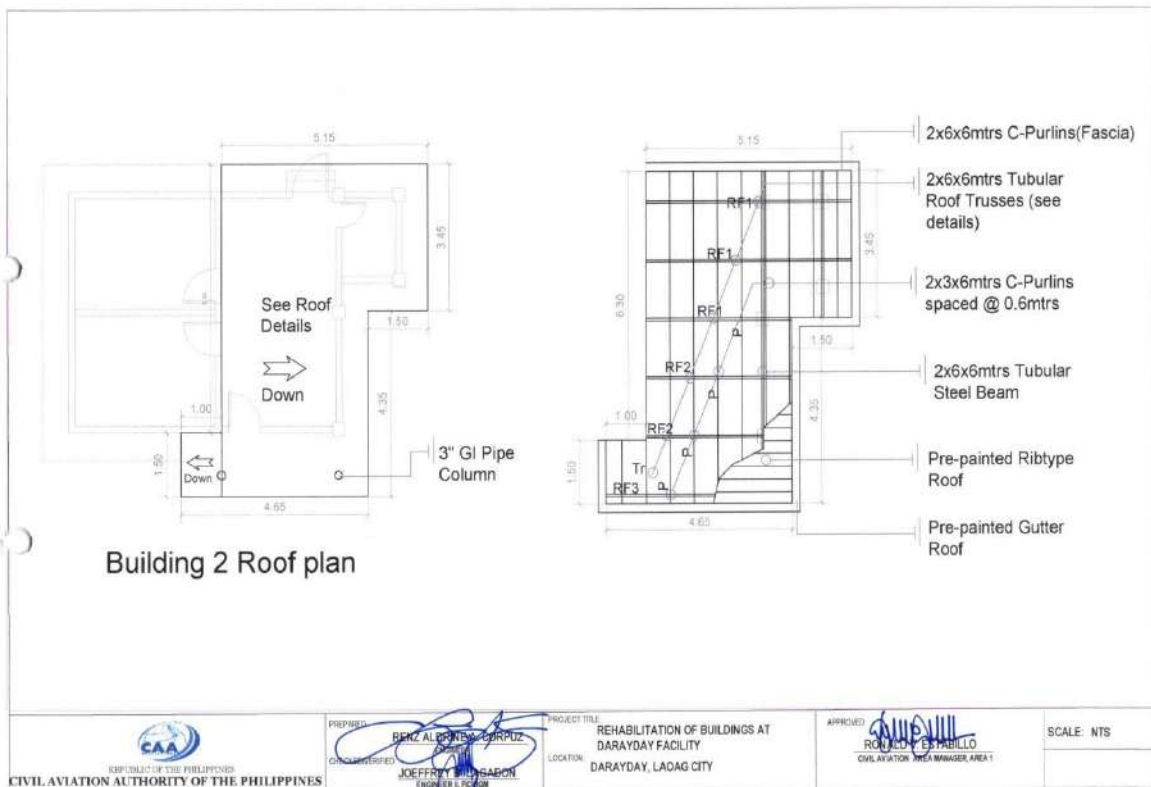
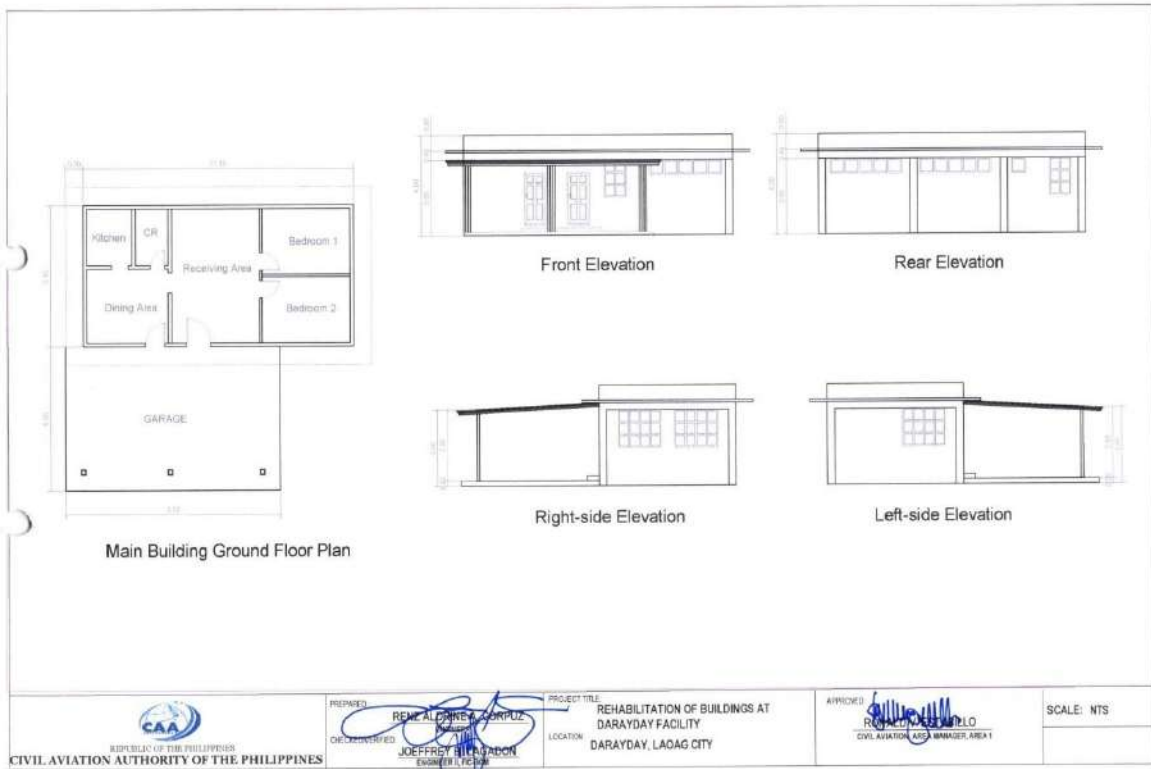

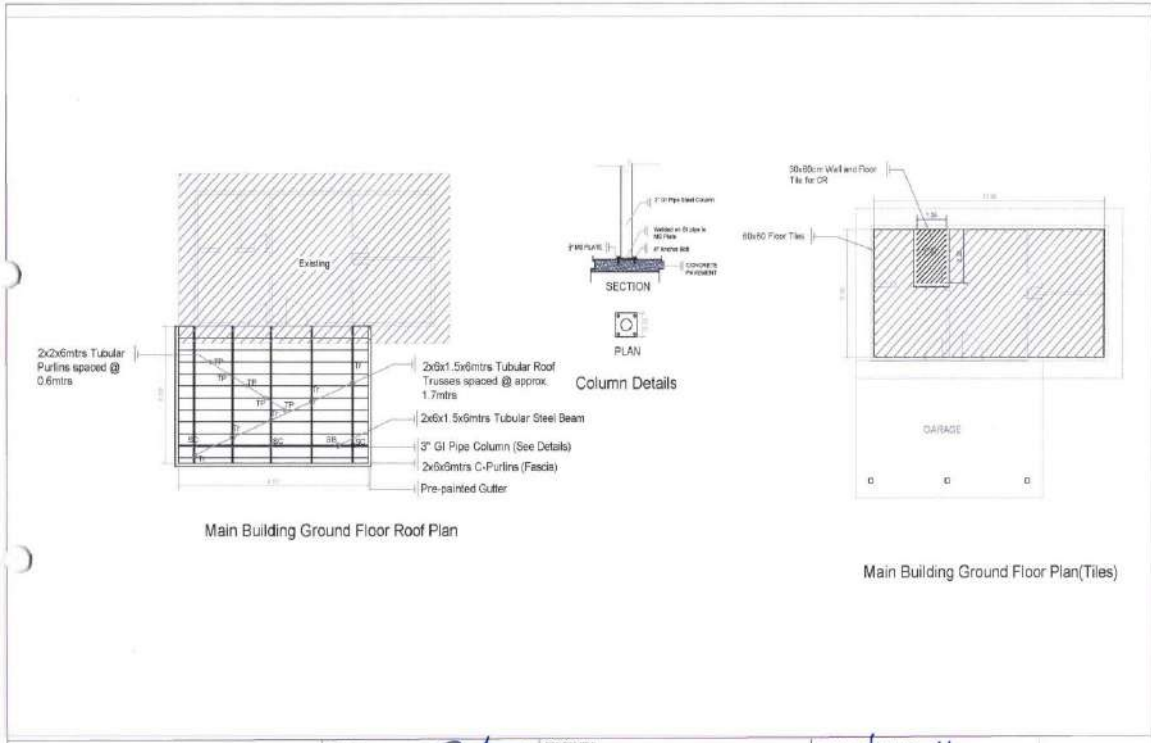
Section VII. Drawings





Main Building Ground Floor Roof Plan



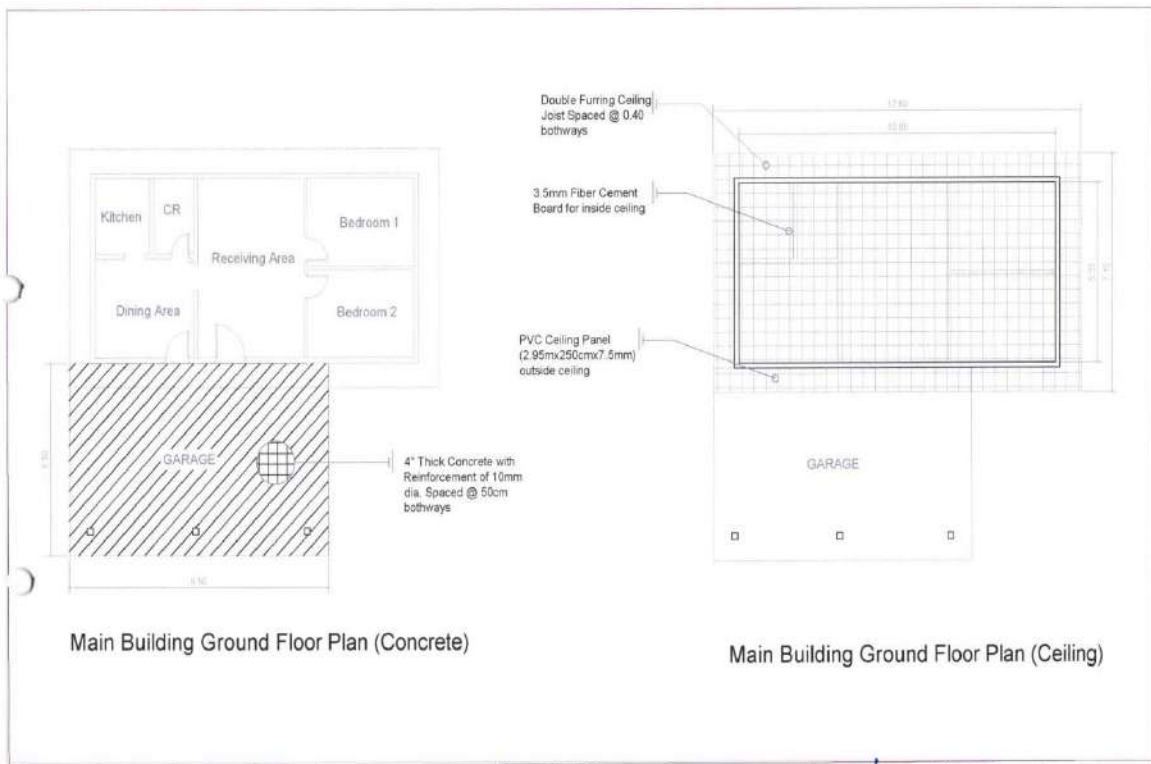

Main Building Ground Floor Plan(Tiles)

 REPUBLIC OF THE PHILIPPINES CIVIL AVIATION AUTHORITY OF THE PHILIPPINES	PREPARED:  RHENALYNNE GORRINZ CHECKED/REVIEWED:  JEFFREY B. MASADON ENGINEER, R.C.S.M.	PROJECT TITLE: REHABILITATION OF BUILDINGS AT DARAYDAY FACILITY LOCATION: DARAYDAY, LAOAG CITY	APPROVED:  RONALDO V. ESTABILLO CIVIL AVIATION AREA MANAGER AREA 1	SCALE: NTS
				



Main Building Ground Floor Plan (Concrete)

Main Building Ground Floor Plan (Ceiling)

 REPUBLIC OF THE PHILIPPINES CIVIL AVIATION AUTHORITY OF THE PHILIPPINES	PREPARED:  RHENALYNNE GORRINZ CHECKED/REVIEWED:  JEFFREY B. MASADON ENGINEER, R.C.S.M.	PROJECT TITLE: REHABILITATION OF BUILDINGS AT DARAYDAY FACILITY LOCATION: DARAYDAY, LAOAG CITY	APPROVED:  RONALDO V. ESTABILLO CIVIL AVIATION AREA MANAGER AREA 1	SCALE: NTS
				



Building 2 Floor Plan

Front Elevation

Rear Elevation

Left-side Elevation

Right-side Elevation

<p>REPUBLIC OF THE PHILIPPINES CIVIL AVIATION AUTHORITY OF THE PHILIPPINES</p>	<p>PREPARED: RENALYN S. CARPUZ</p> <p>CHECKED: JOEFREY B. DAGADON ENGINEER, P.E. No. 10000</p>	<p>PROJECT TITLE: REHABILITATION OF BUILDINGS AT DARAYDAY FACILITY</p> <p>LOCATION: DARAYDAY, LAOAG CITY</p>	<p>APPROVED: RONALDO Y. SANTIAGO CIVIL AVIATION AREA MANAGER, AREA 1</p>	<p>SCALE: NTS</p>
	<p>REHABILITATION OF BUILDINGS AT DARAYDAY FACILITY</p>			

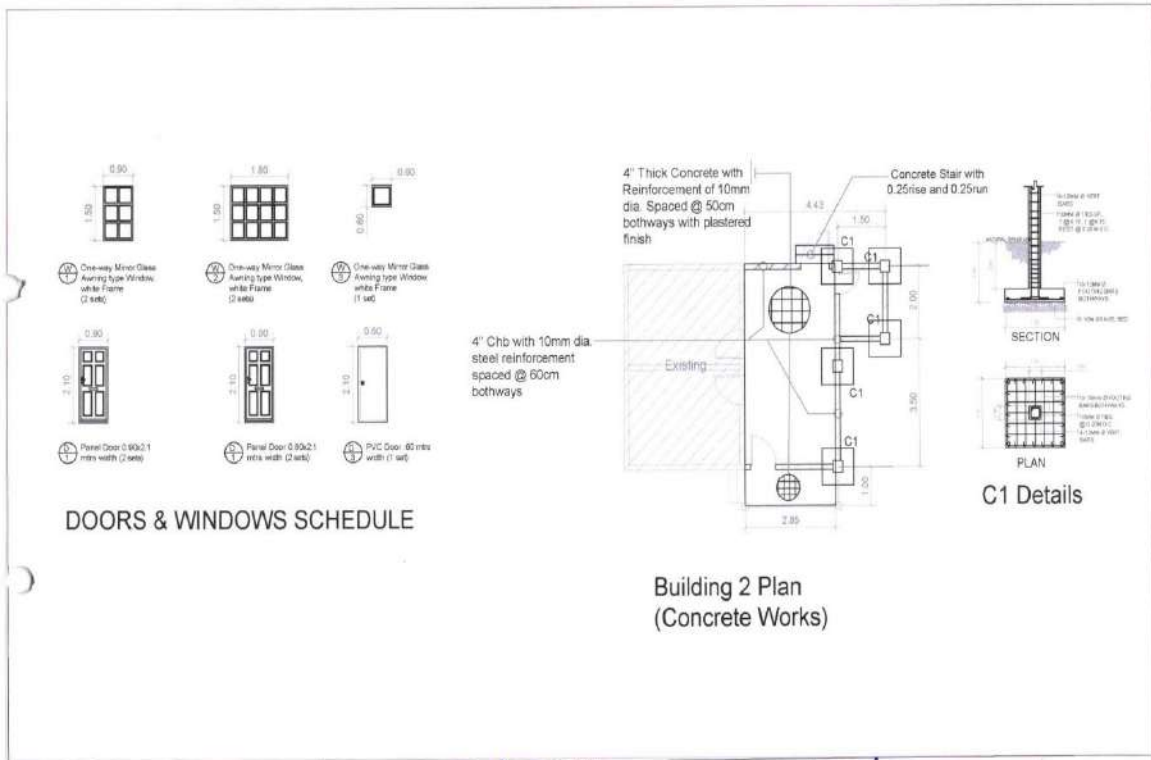

DOORS & WINDOWS SCHEDULE

Building 2 Plan
(Concrete Works)

C1 Details

<p>REPUBLIC OF THE PHILIPPINES CIVIL AVIATION AUTHORITY OF THE PHILIPPINES</p>	<p>PREPARED: RENALYN S. CARPUZ</p> <p>CHECKED: JOEFREY B. DAGADON ENGINEER, P.E. No. 10000</p>	<p>PROJECT TITLE: REHABILITATION OF BUILDINGS AT DARAYDAY FACILITY</p> <p>LOCATION: DARAYDAY, LAOAG CITY</p>	<p>APPROVED: RONALDO Y. SANTIAGO CIVIL AVIATION AREA MANAGER, AREA 1</p>	<p>SCALE: NTS</p>
	<p>REHABILITATION OF BUILDINGS AT DARAYDAY FACILITY</p>			

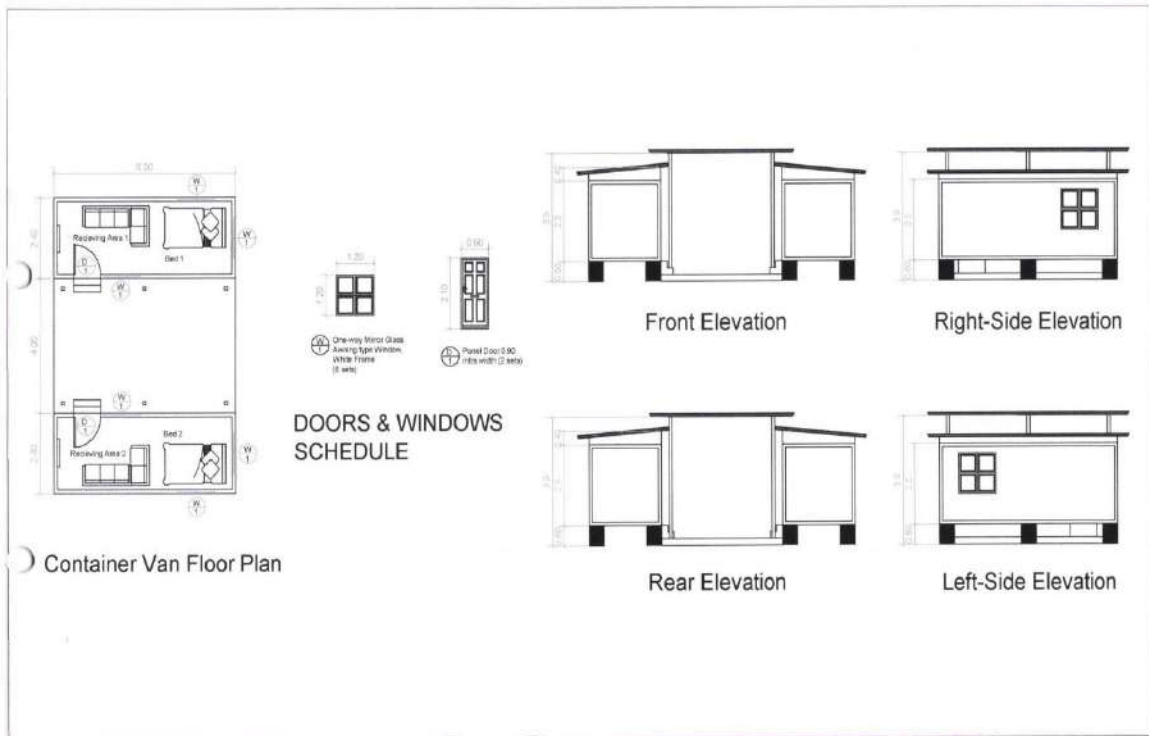

<p>REPUBLIC OF THE PHILIPPINES CIVIL AVIATION AUTHORITY OF THE PHILIPPINES</p>	<p>PREPARED BY: RENZ ALONZA CORPUZ</p>	<p>PROJECT TITLE: REHABILITATION OF BUILDINGS AT DARAYDAY FACILITY</p>	<p>APPROVED BY: RONALDO W. ESTABILLO</p>	<p>SCALE: NTS</p>
	<p>CHECKED/VERIFIED BY: JOEFFRE W. LAGADON</p>	<p>LOCATION: DARAYDAY, LAOAG CITY</p>	<p>CIVIL AVIATION AREA MANAGER, AREA 1</p>	

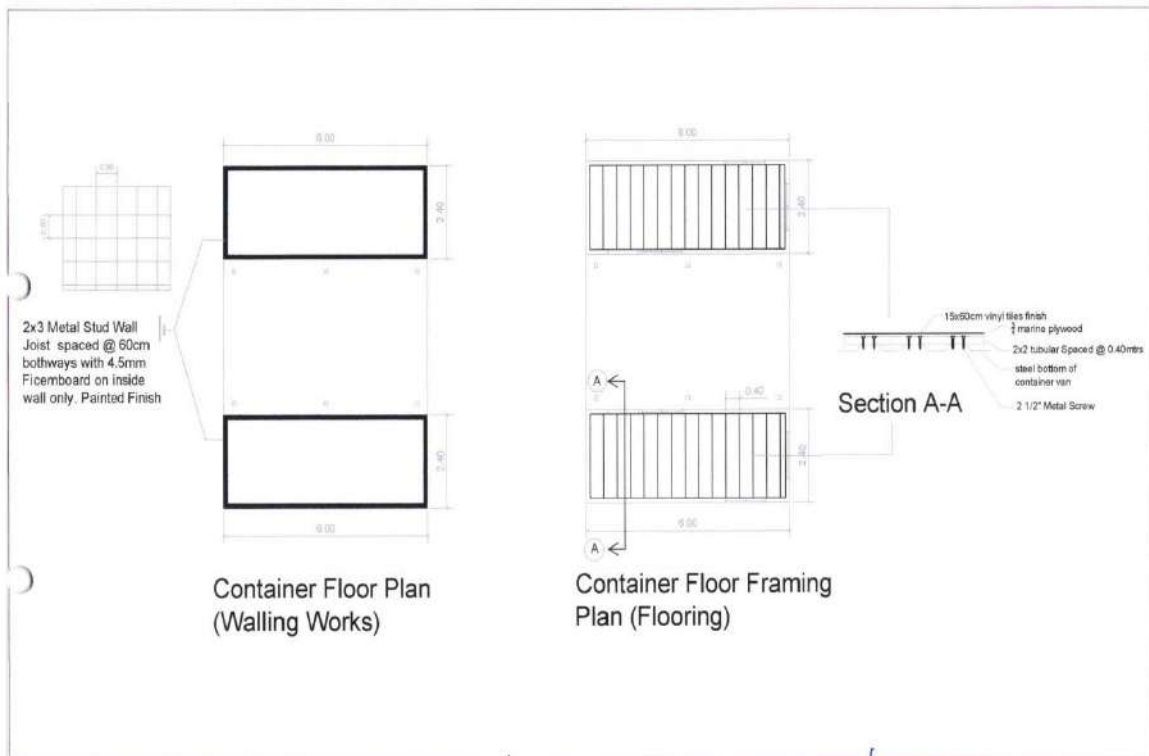

<p>REPUBLIC OF THE PHILIPPINES CIVIL AVIATION AUTHORITY OF THE PHILIPPINES</p>	<p>PREPARED BY: RENZ ALONZA CORPUZ</p>	<p>PROJECT TITLE: REHABILITATION OF BUILDINGS AT DARAYDAY FACILITY</p>	<p>APPROVED BY: RONALDO W. ESTABILLO</p>	<p>SCALE: NTS</p>
	<p>CHECKED/VERIFIED BY: JOEFFRE W. LAGADON</p>	<p>LOCATION: DARAYDAY, LAOAG CITY</p>	<p>CIVIL AVIATION AREA MANAGER, AREA 1</p>	

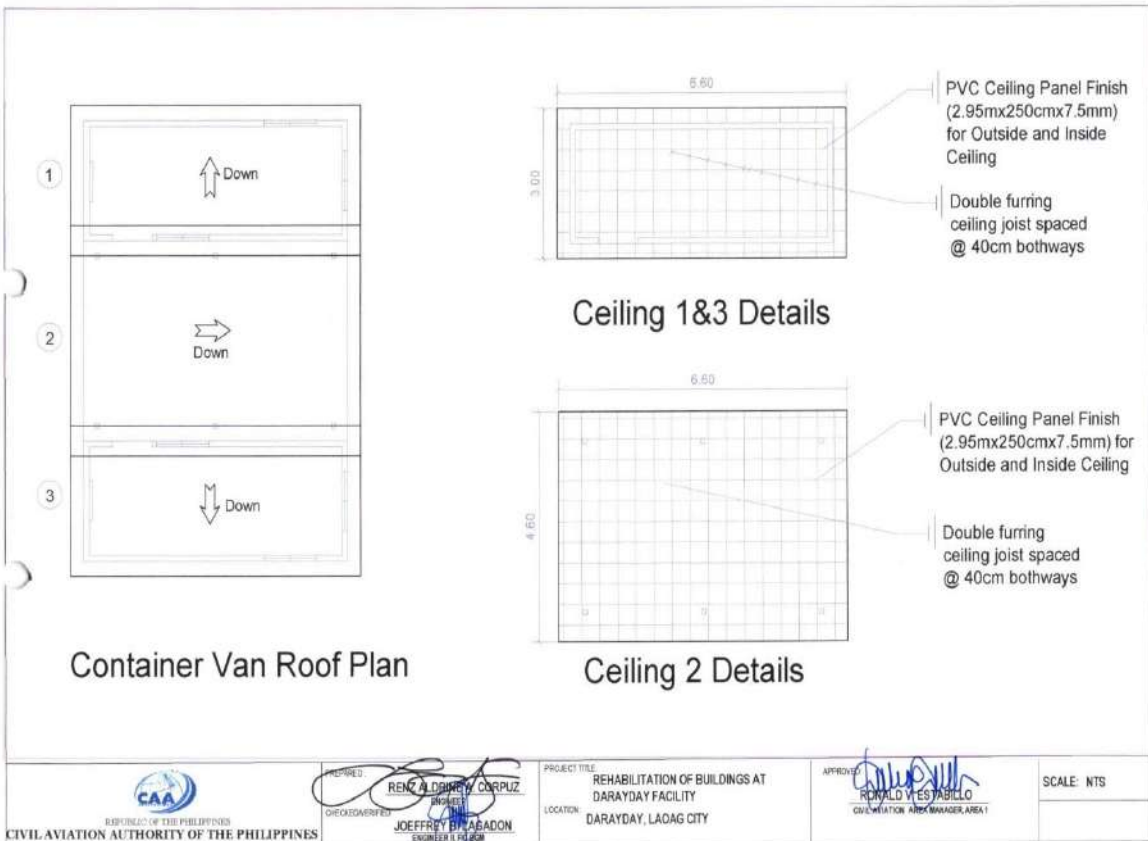
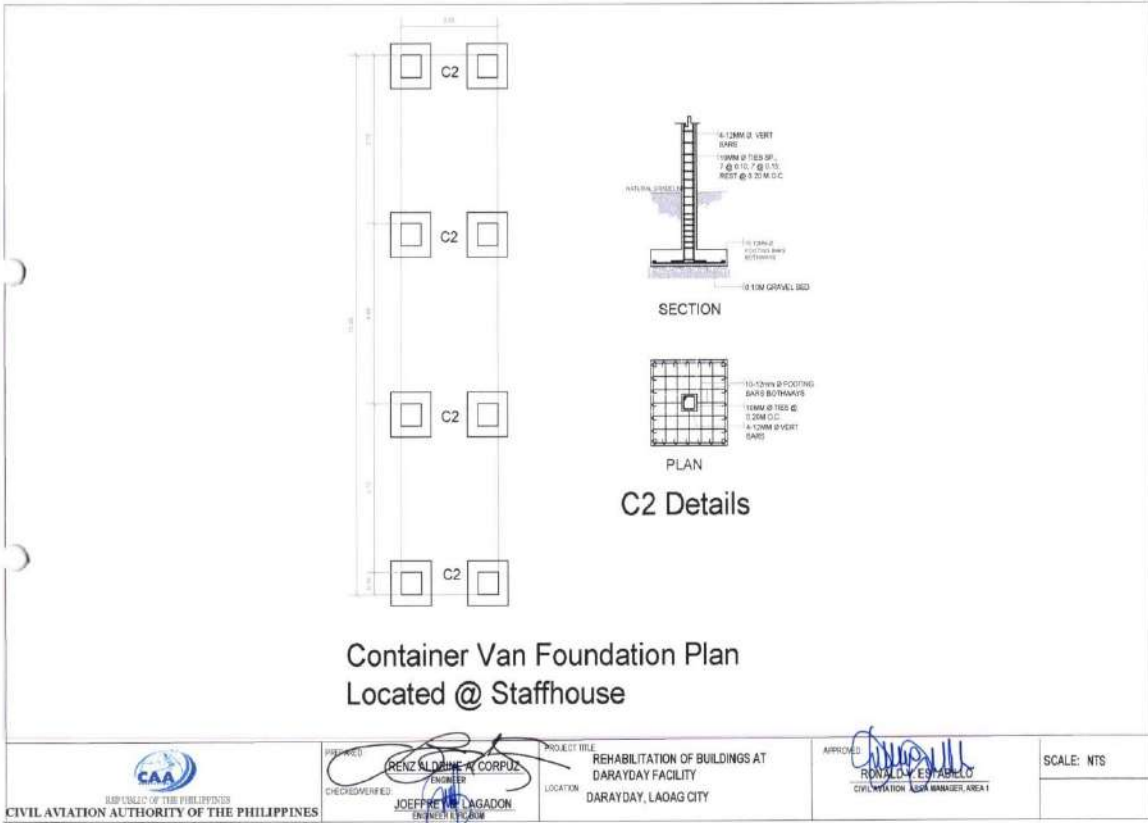

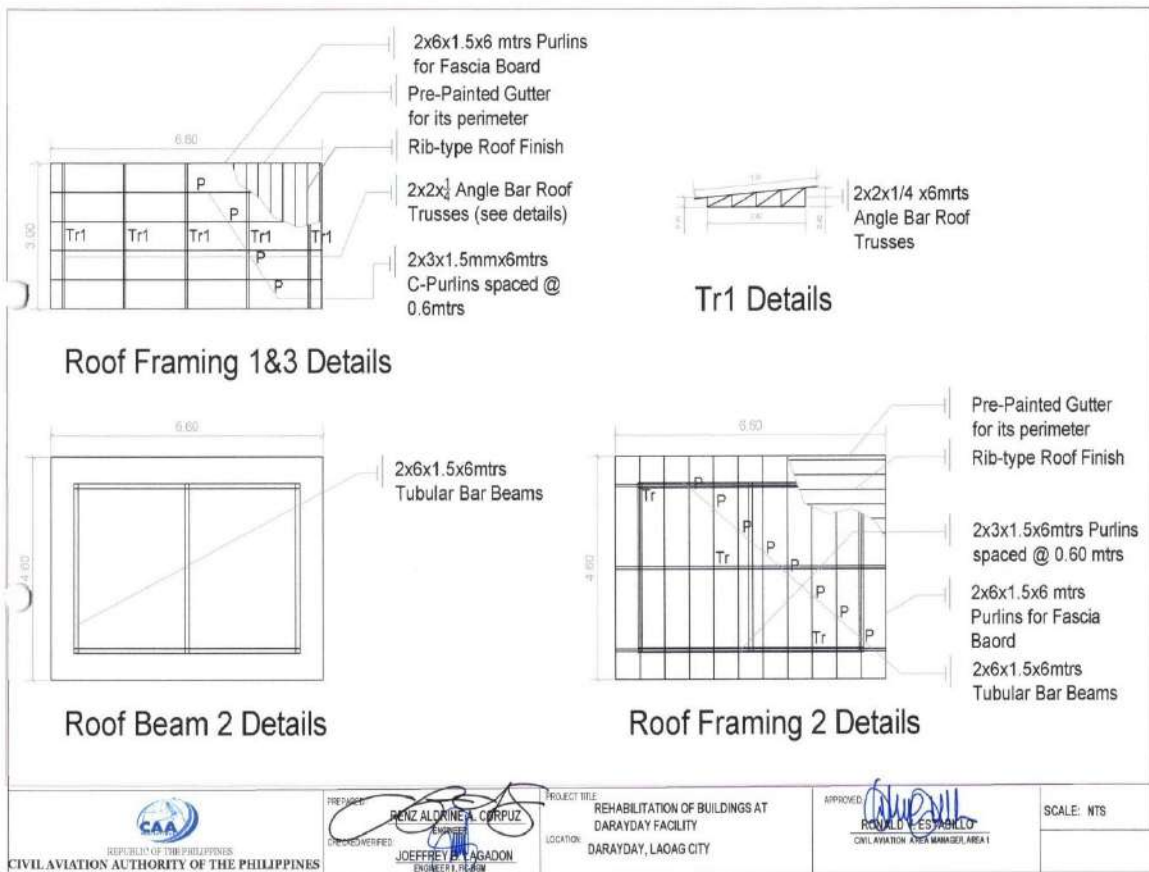
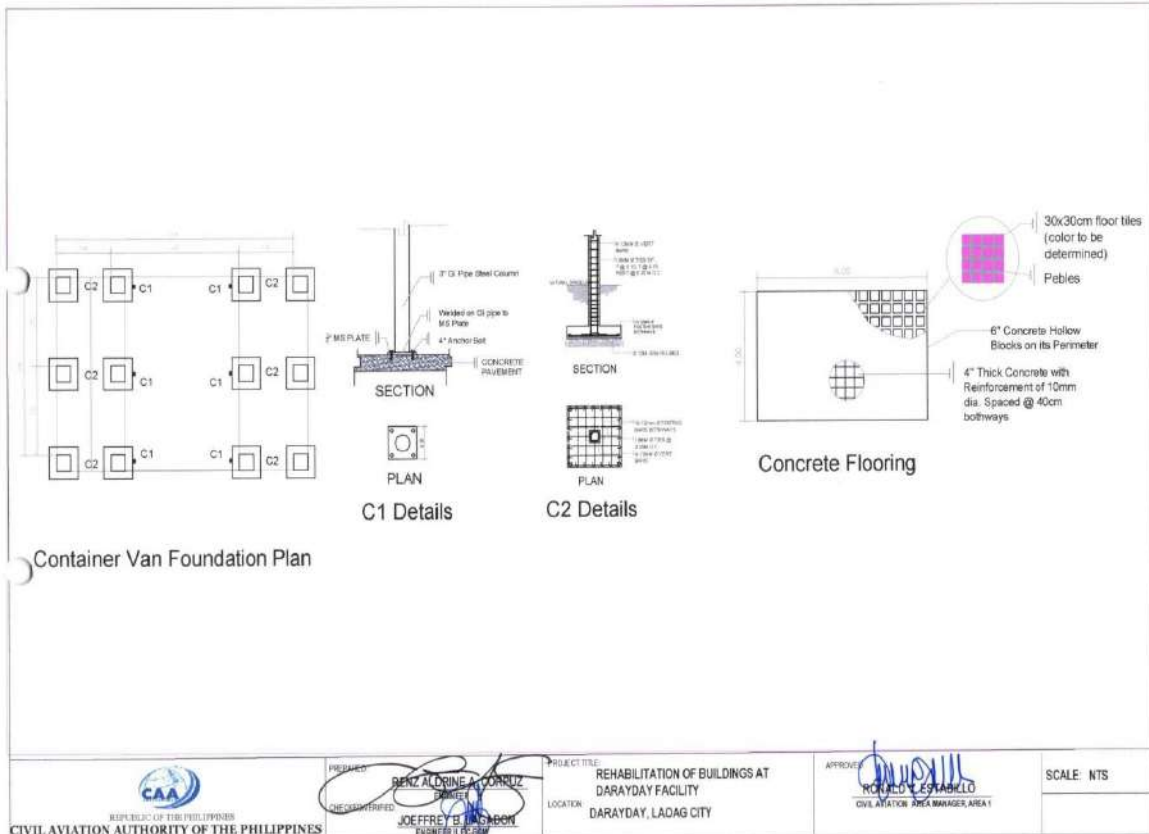

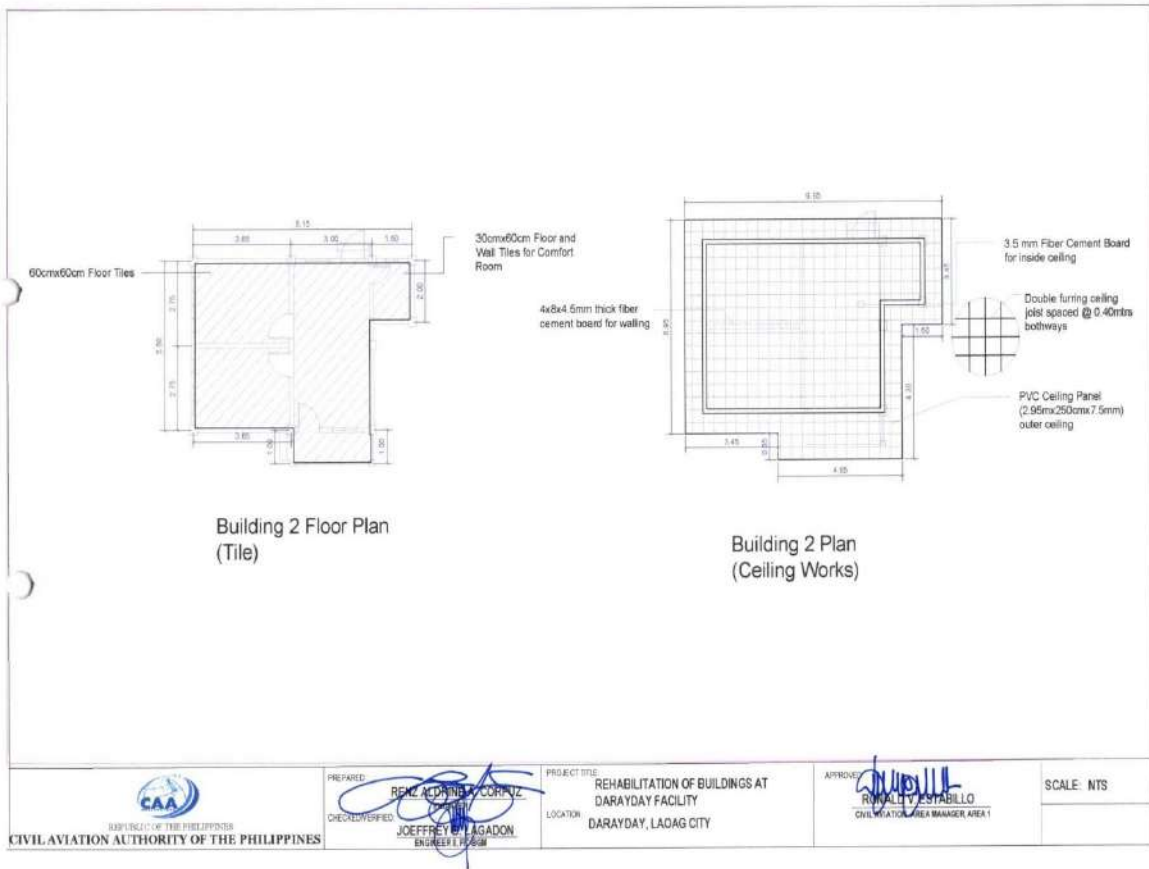
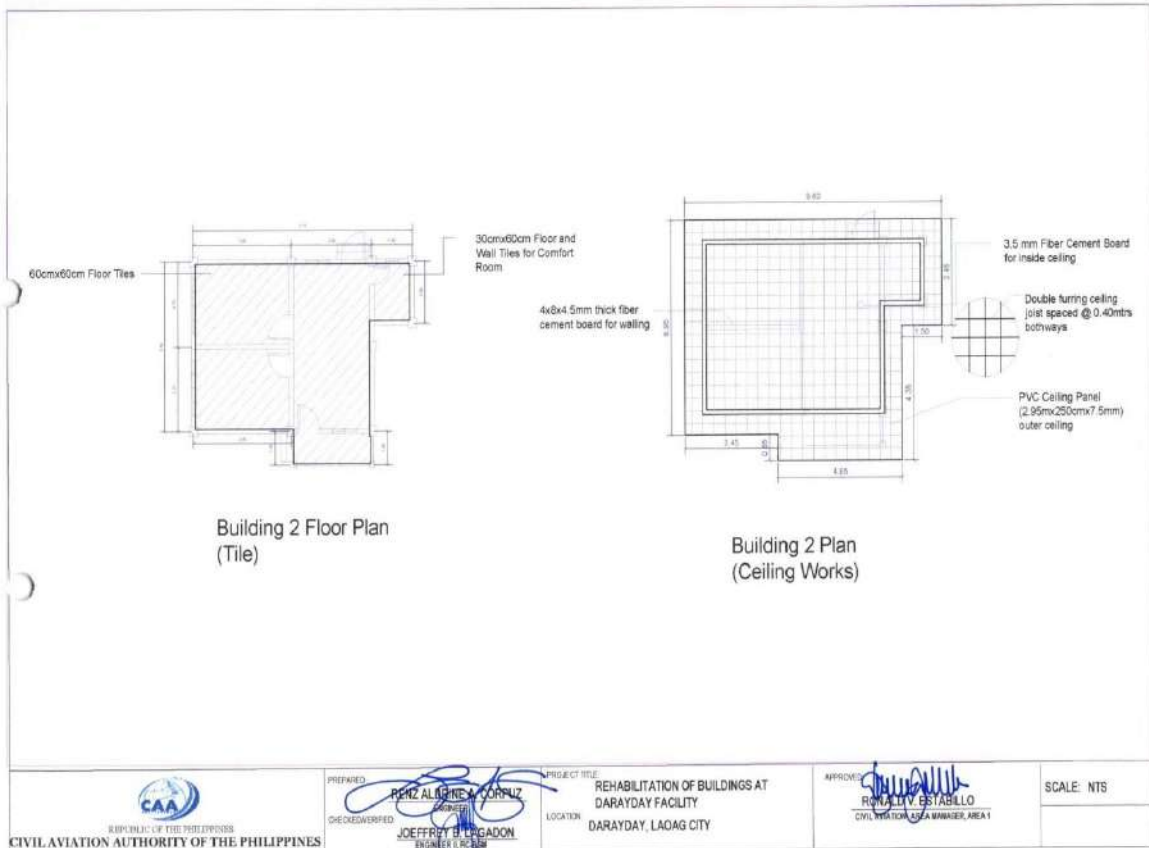

4" Thick Concrete with Reinforcement of 10mm dia. Spaced @ 50cm bothways

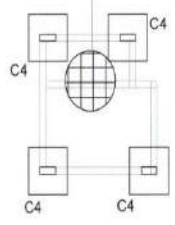

Public CR Foundation Plan

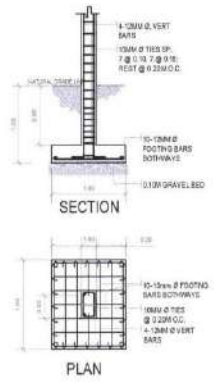

C4 Details



CR FLOOR PLAN (TILE)

Use 30x60cm Matt Tiles for Floor and Wall

<p>REPUBLIC OF THE PHILIPPINES CIVIL AVIATION AUTHORITY OF THE PHILIPPINES</p>	<p>PREPARED BY: RENZ ALDRINE S. CORPUZ CHECKED BY: JOFFREY B. MAGADON ENGINEER & P.C. 5041</p>	<p>PROJECT TITLE: REHABILITATION OF BUILDINGS AT DARAYDAY FACILITY LOCATION: DARAYDAY, LAOAG CITY</p>	<p>APPROVED BY: RONALDO V. ESTABILLO CIVIL AVIATION AREA MANAGER, AREA 1</p>	<p>SCALE: NTS</p>
	<p>DATE: _____</p>			

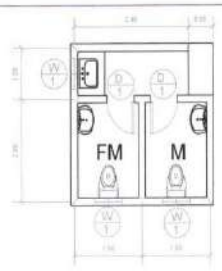

CR FLOOR PLAN

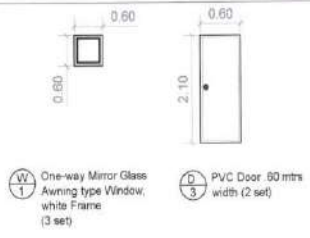

DOORS & WINDOWS SCHEDULE

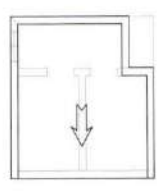

CR FLOOR ROOF PLAN

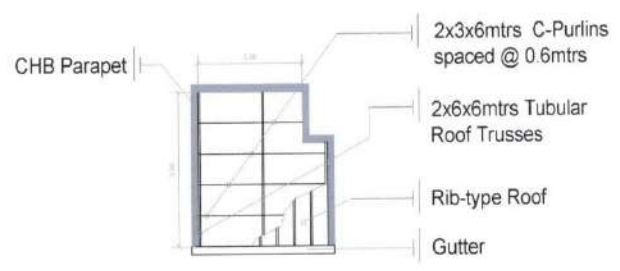

CR FLOOR ROOF FRAMING PLAN

<p>REPUBLIC OF THE PHILIPPINES CIVIL AVIATION AUTHORITY OF THE PHILIPPINES</p>	<p>PREPARED BY: RENZ ALDRINE S. CORPUZ CHECKED BY: JOFFREY B. MAGADON ENGINEER & P.C. 5041</p>	<p>PROJECT TITLE: REHABILITATION OF BUILDINGS AT DARAYDAY FACILITY LOCATION: DARAYDAY, LAOAG CITY</p>	<p>APPROVED BY: RONALDO V. ESTABILLO CIVIL AVIATION AREA MANAGER, AREA 1</p>	<p>SCALE: NTS</p>
	<p>DATE: _____</p>			

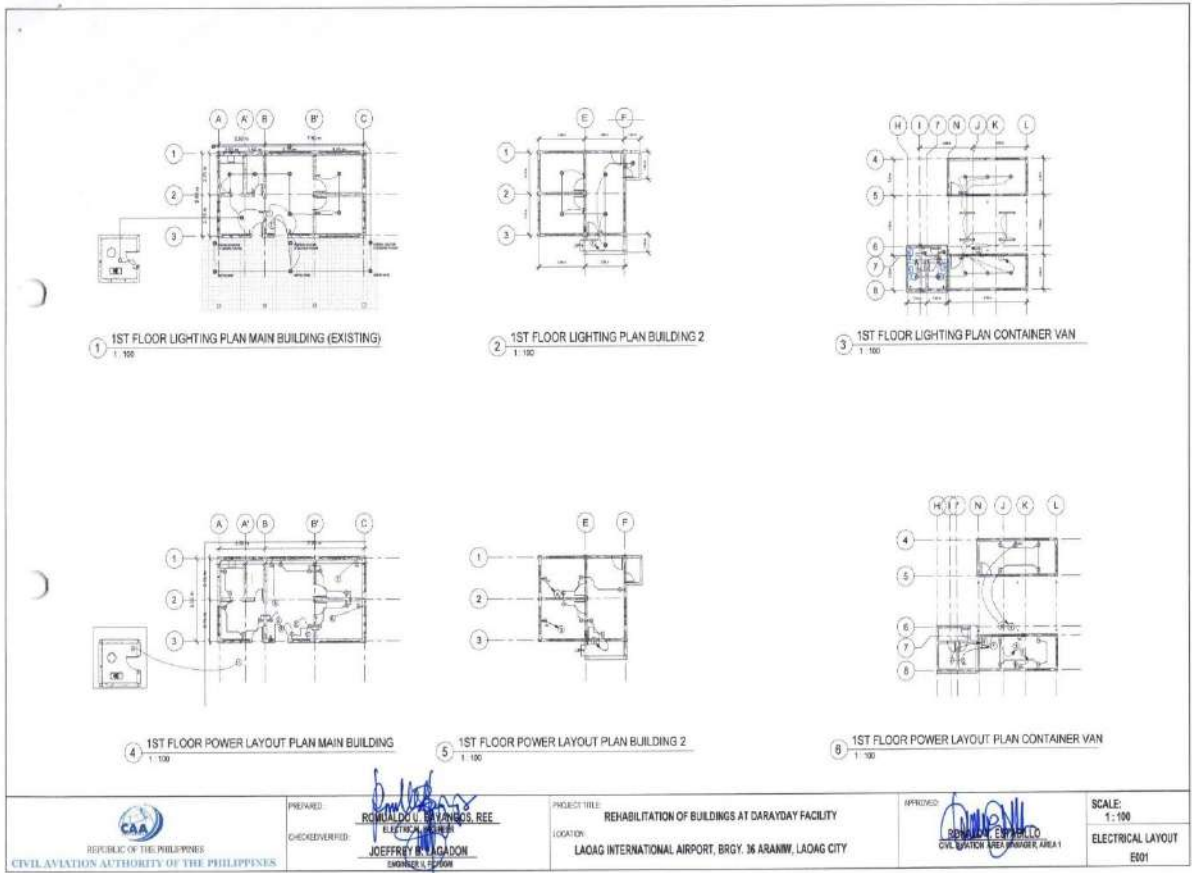

<p>REPUBLIC OF THE PHILIPPINES CIVIL AVIATION AUTHORITY OF THE PHILIPPINES</p>	<p>PREPARED: ROMALDO U. BAYANDOS, REE ELECTRICAL ENGINEER</p> <p>CHECKED/VERIFIED: JEFFREY B. MAGADON ENGINEER</p>	<p>PROJECT TITLE: REHABILITATION OF BUILDINGS AT DARAYDAY FACILITY</p> <p>LOCATION: LAGAG INTERNATIONAL AIRPORT, BRGY. 36 ARANW, LAGAG CITY</p>	<p>APPROVED: ROMALDO U. BAYANDOS ELECTRICAL ENGINEER, AREA 1</p>	<p>SCALE: 1:100</p> <p>ELECTRICAL LAYOUT E001</p>
--	--	---	---	---

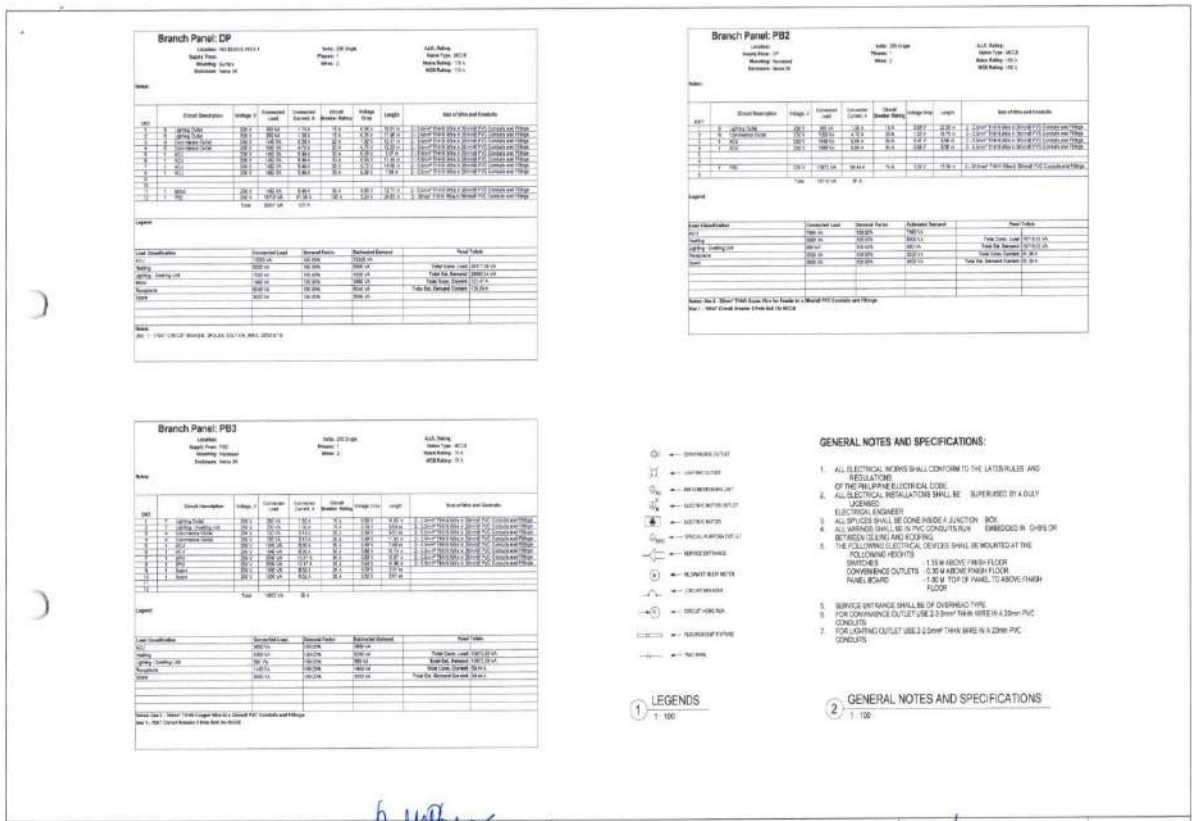

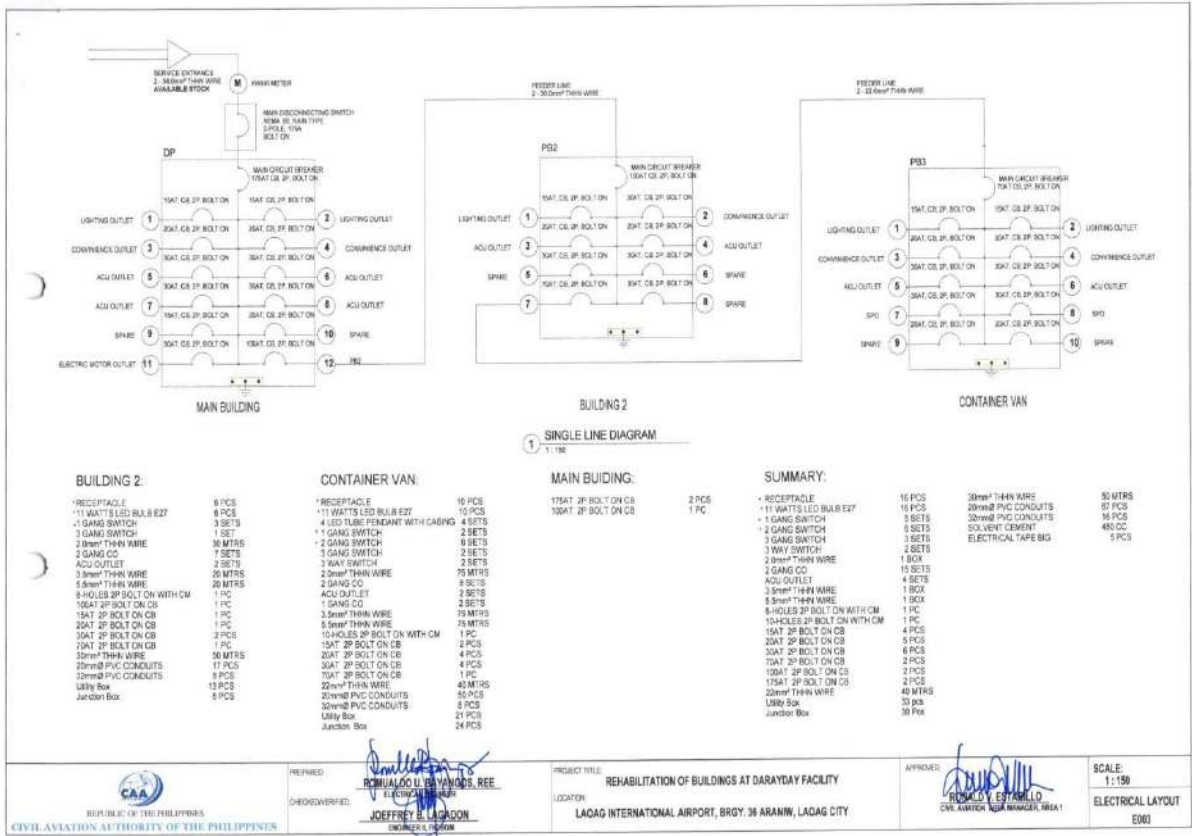

PREPARED: ROMUALDO S. BARRALES, REE
 CHECKED/VERIFIED: JOEFRY S. LAGASON, ENGINEER 1 (ELECTRICAL)
 PROJECT TITLE: REHABILITATION OF BUILDINGS AT DARAYDAY FACILITY
 LOCATION: LAOAG INTERNATIONAL AIRPORT, BRGY. 36 ARANIM, LAOAG CITY
 APPROVED: ROMUALDO S. BARRALES, CIVIL AVIATION AREA MANAGER, AREA 1
 SCALE: 1:150
 ELECTRICAL LAYOUT E003

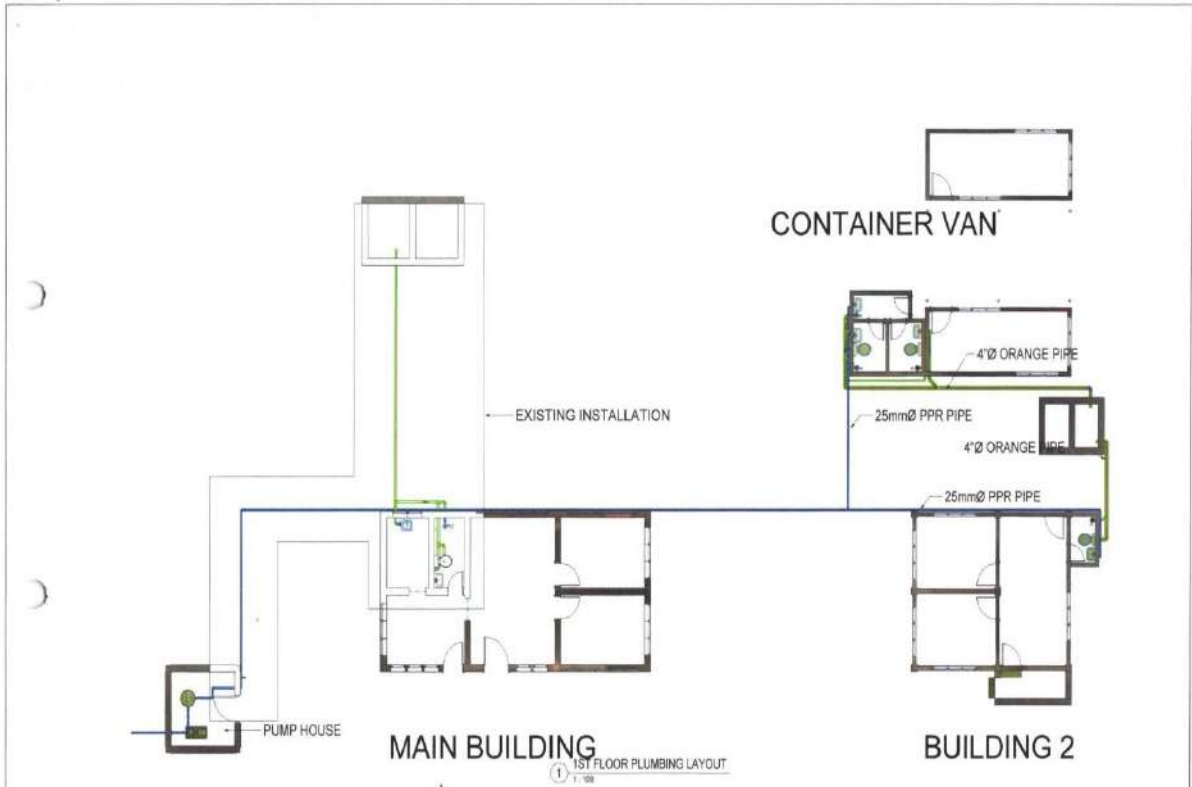

PREPARED: ROMUALDO S. BARRALES, REE
 CHECKED/VERIFIED: JOEFRY S. LAGASON, ENGINEER 1 (ELECTRICAL)
 PROJECT TITLE: REHABILITATION OF BUILDINGS AT DARAYDAY FACILITY
 LOCATION: LAOAG INTERNATIONAL AIRPORT, BRGY. 36 ARANIM, LAOAG CITY
 APPROVED: ROMUALDO S. BARRALES, CIVIL AVIATION AREA MANAGER, AREA 1
 SCALE: 1:100
 PLUMBING LAYOUT PL01

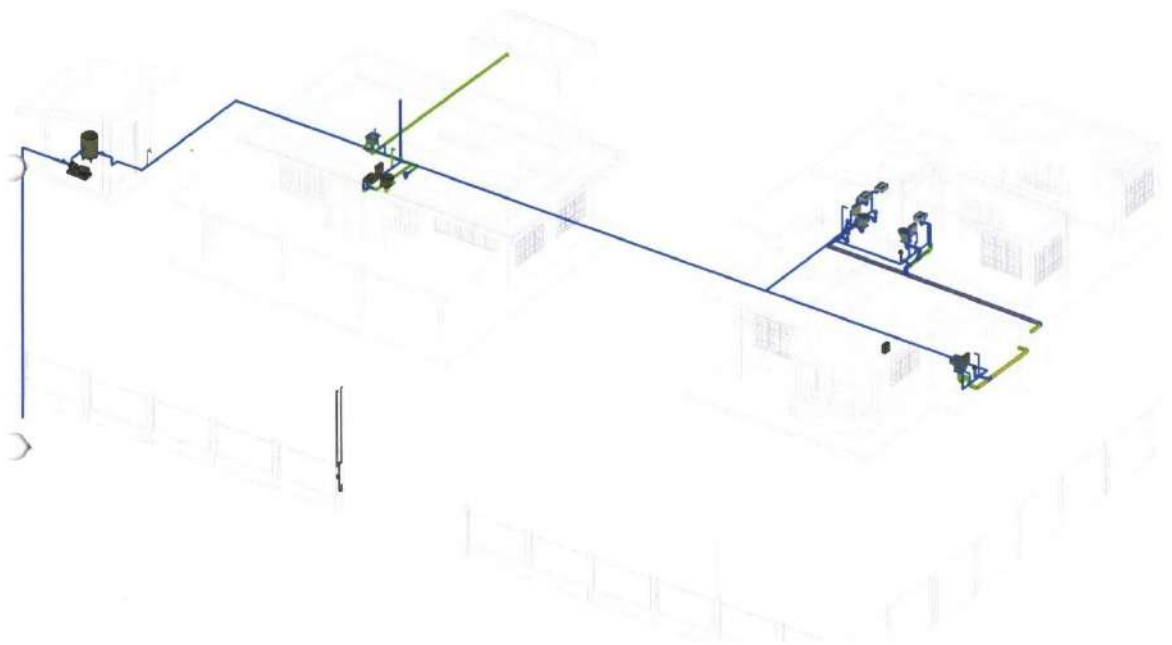
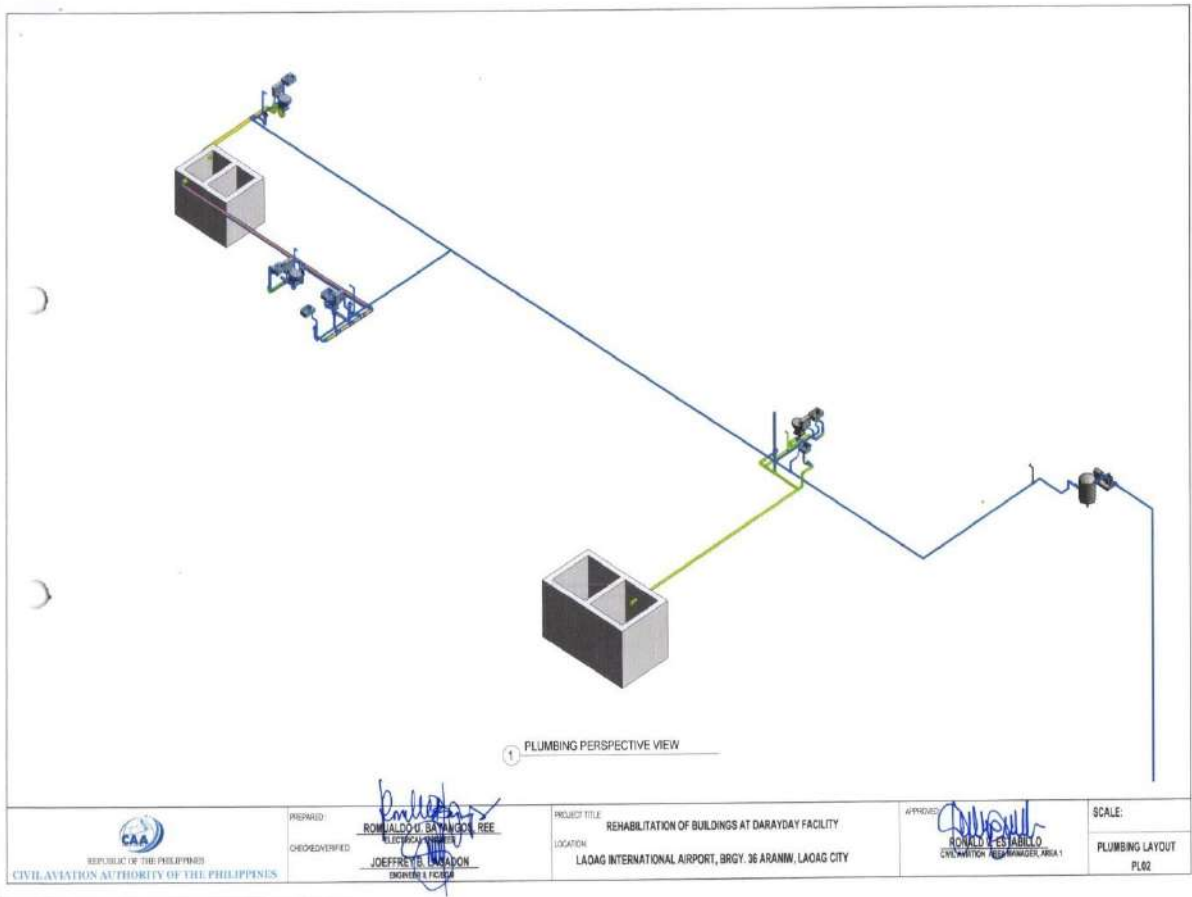

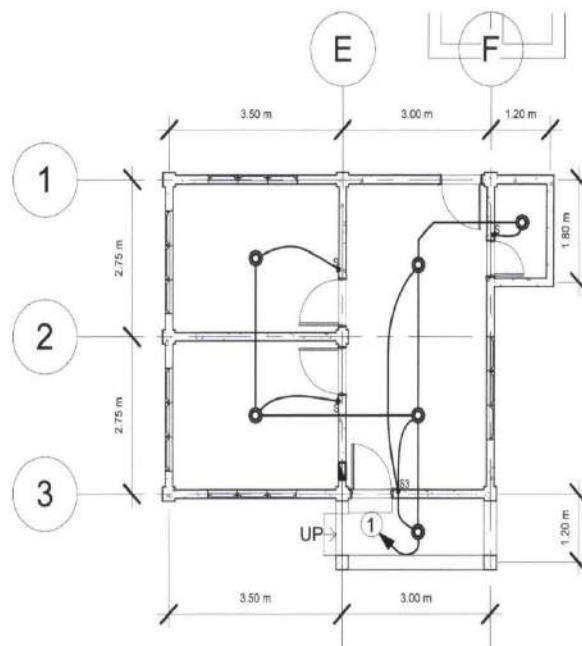
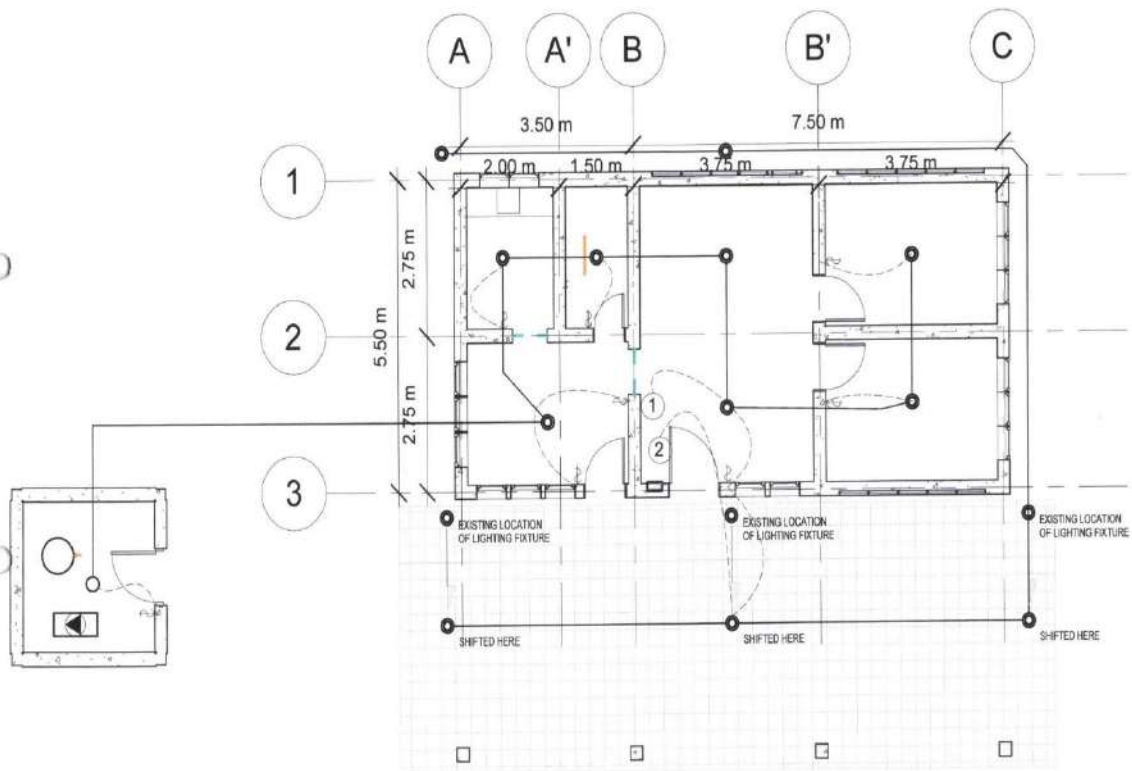

1ST FLOOR LIGHTING PLAN BUILDING 2

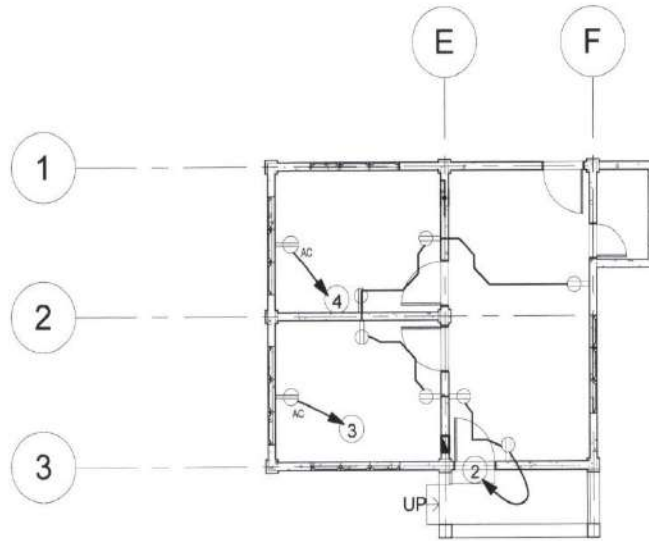

BUILDING 2

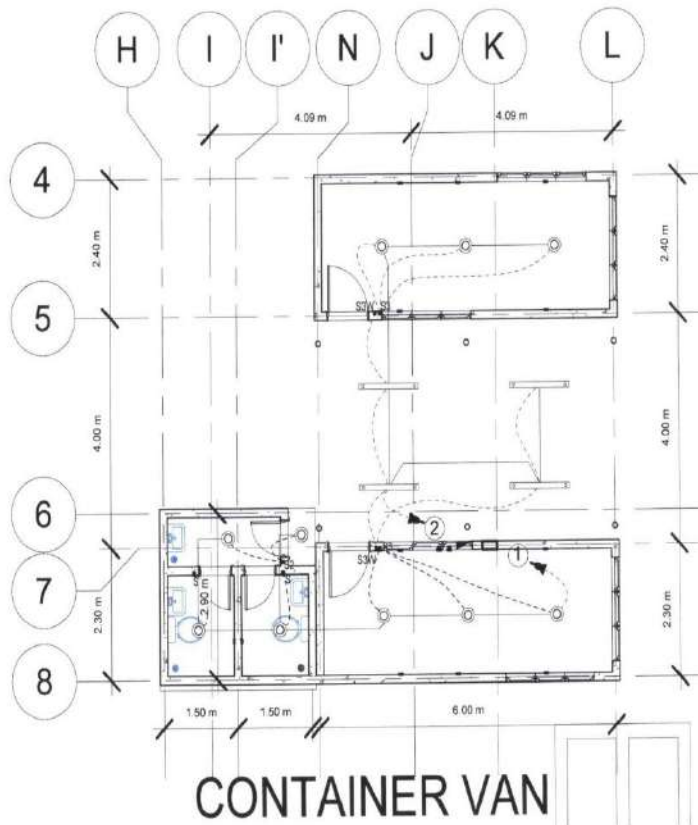

CONTAINER VAN

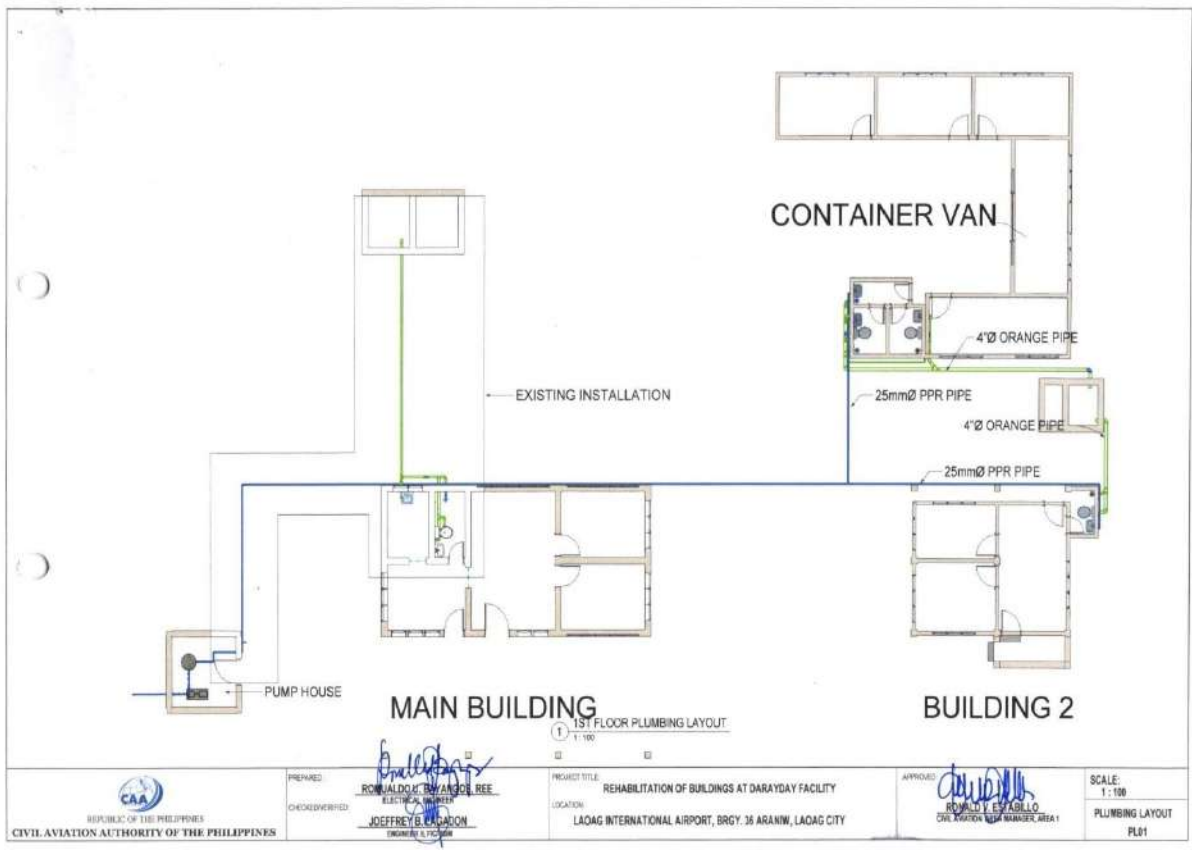
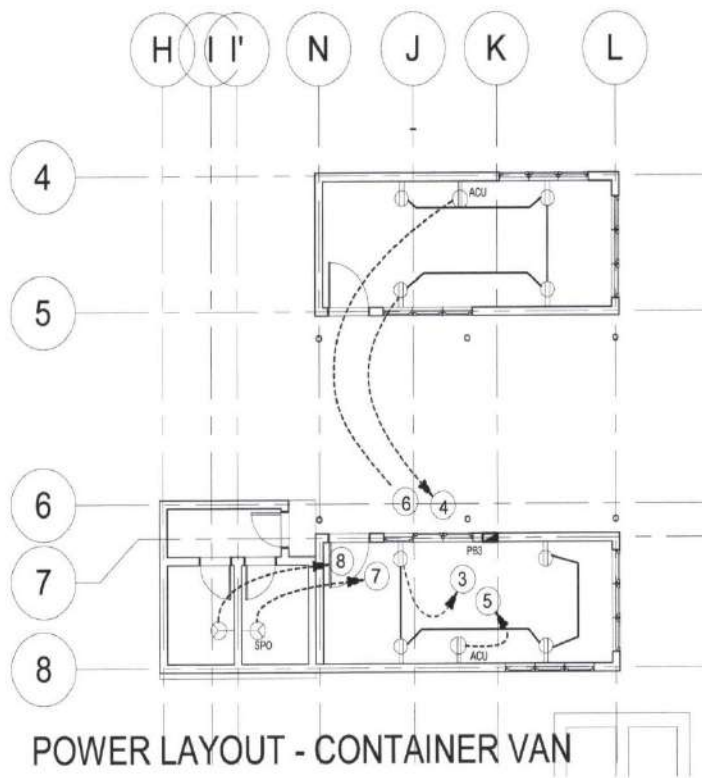

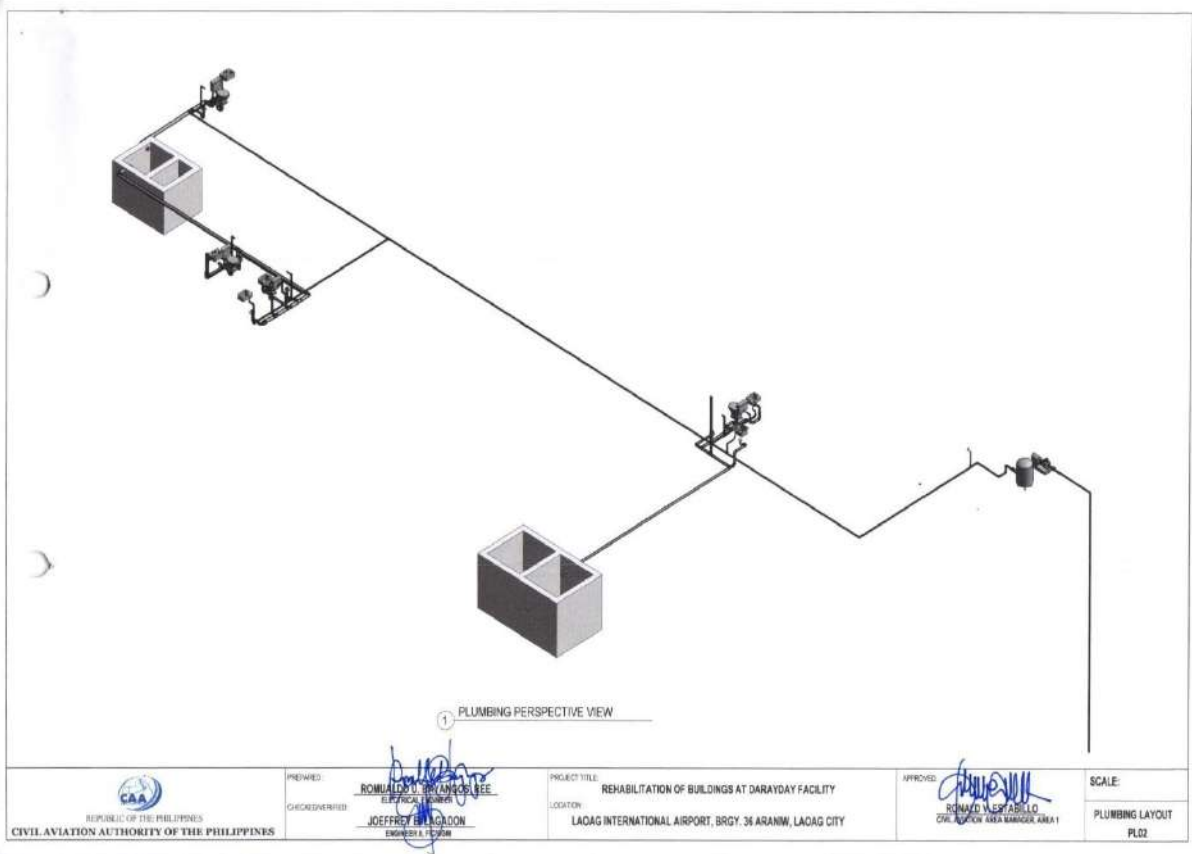
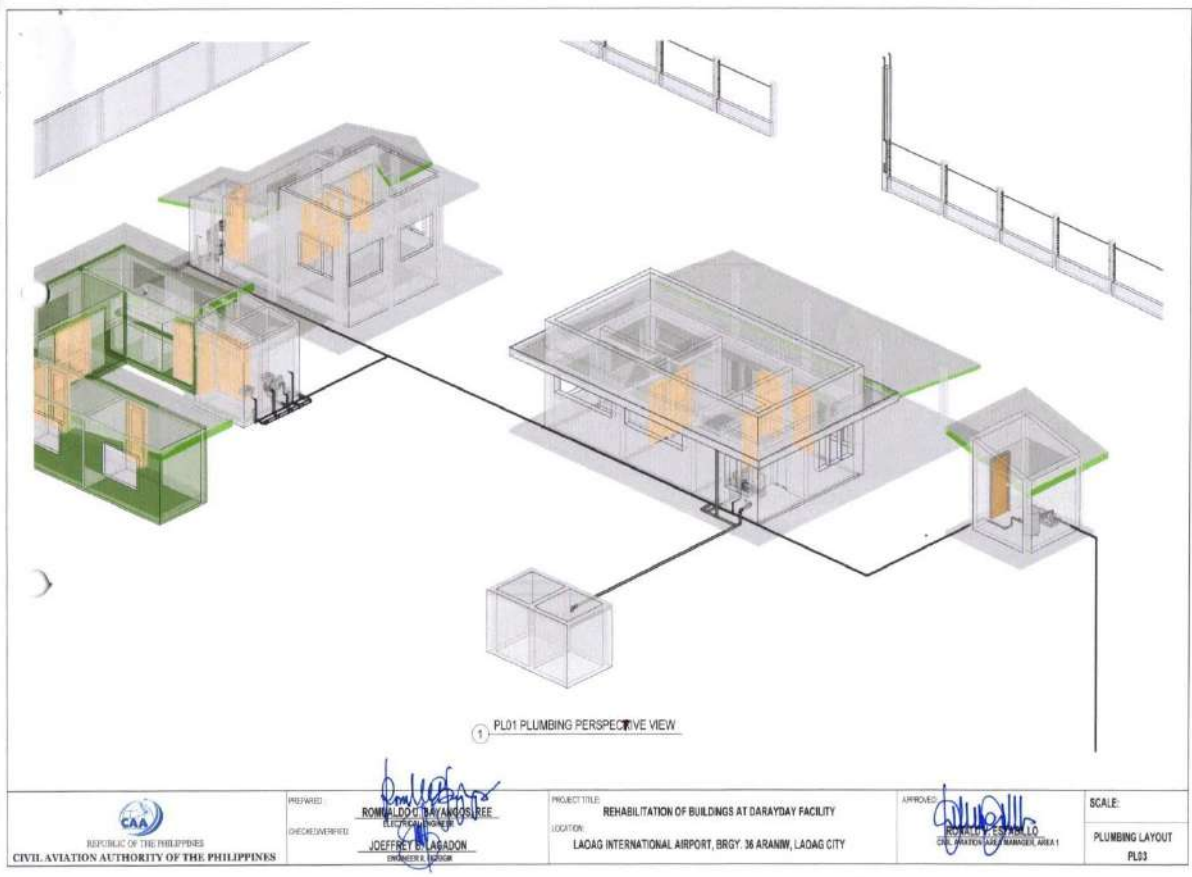

CONTAINER VAN

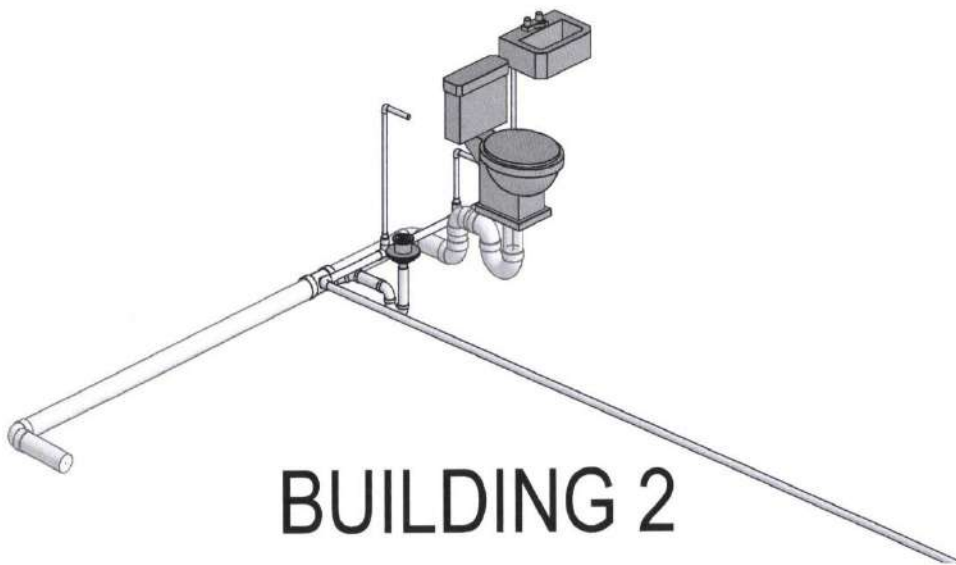
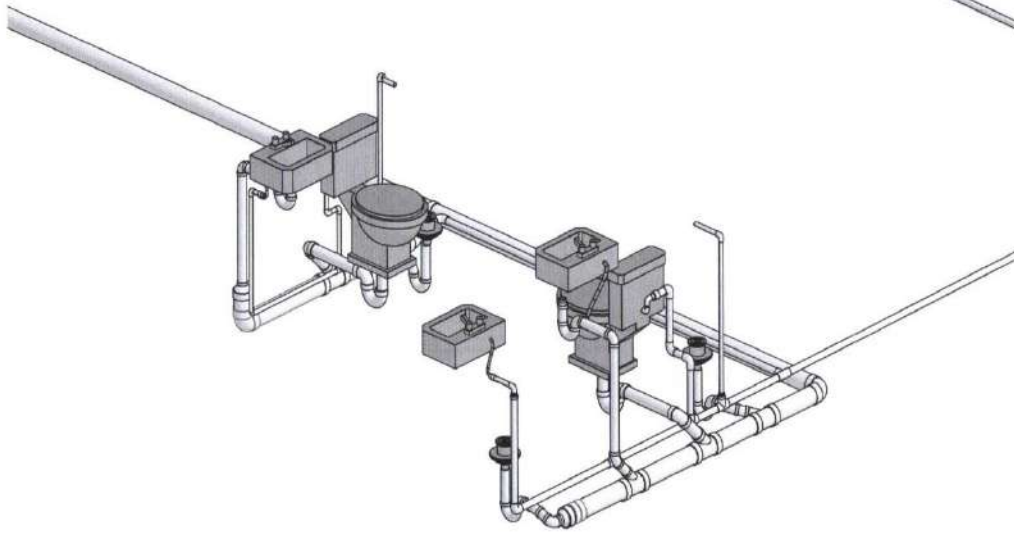

BUILDING 2

Section VIII. Bill of Quantities

Notes on the Bill of Quantities

Objectives

The objectives of the Bill of Quantities are:

- a. to provide sufficient information on the quantities of Works to be performed to enable Bids to be prepared efficiently and accurately; and
- b. when a Contract has been entered into, to provide a priced Bill of Quantities for use in the periodic valuation of Works executed.

In order to attain these objectives, Works should be itemized in the Bill of Quantities in sufficient detail to distinguish between the different classes of Works, or between Works of the same nature carried out in different locations or in other circumstances which may give rise to different considerations of cost. Consistent with these requirements, the layout and content of the Bill of Quantities should be as simple and brief as possible.

Daywork Schedule

A Daywork Schedule should be included only if the probability of unforeseen work, outside the items included in the Bill of Quantities, is high. To facilitate checking by the Entity of the realism of rates quoted by the Bidders, the Daywork Schedule should normally comprise the following:

- a. A list of the various classes of labor, materials, and Constructional Plant for which basic daywork rates or prices are to be inserted by the Bidder, together with a statement of the conditions under which the Contractor will be paid for work executed on a daywork basis.
- b. Nominal quantities for each item of Daywork, to be priced by each Bidder at Daywork rates as Bid. The rate to be entered by the Bidder against each basic Daywork item should include the Contractor's profit, overheads, supervision, and other charges.

Provisional Sums

A general provision for physical contingencies (quantity overruns) may be made by including a provisional sum in the Summary Bill of Quantities. Similarly, a contingency allowance for possible price increases should be provided as a provisional sum in the Summary Bill of Quantities. The inclusion of such provisional sums often facilitates budgetary approval by avoiding the need to request periodic supplementary approvals as the future need arises. Where such provisional sums or contingency allowances are used, the SCC should state the manner in which they will be used, and under whose authority (usually the Procuring Entity's Representative's).

The estimated cost of specialized work to be carried out, or of special goods to be supplied, by other contractors should be indicated in the relevant part of the Bill of Quantities as a particular provisional sum with an appropriate brief description. A separate procurement procedure is normally carried out by the Procuring Entity to select such specialized contractors. To provide an element of competition among the Bidders in respect of any facilities, amenities, attendance, etc., to be provided by the successful Bidder as prime Contractor for the use and convenience of the specialist contractors, each related provisional sum should be followed by an item in the Bill of Quantities inviting the Bidder to quote a sum for such amenities, facilities, attendance, etc.

Signature Box

A signature box shall be added at the bottom of each page of the Bill of Quantities where the authorized representative of the Bidder shall affix his signature. Failure of the authorized representative to sign each and every page of the Bill of Quantities shall be a cause for rejection of his bid.

These Notes for Preparing a Bill of Quantities are intended only as information for the Procuring Entity or the person drafting the Bidding Documents. They should not be included in the final documents.

BILL OF QUANTITIES

(Attach Company Letterhead/Logo)

BILL OF QUANTITIES

PROJECT: Rehabilitation of Buildings at Darayday Facility

LOCATION: Laoag City

ITEM NO.	DESCRIPTION	QTY	UNIT	UNIT PRICE	AMOUNT
I.	HAULING	1	lot		
	Amount in Words				
II.	CONCRETE WORKS	1	lot		
	Amount in Words				
III.	TILE WORKS	1	lot		
	Amount in Words				
IV.	ROOFING WORKS	1	lot		
	Amount in Words				
V.	CEILING WORKS	1	lot		
	Amount in Words				
VI.	STEEL WORKS	1	lot		
	Amount in Words				
VII.	FLOORING WORKS	1	lot		
	Amount in Words				
VIII.	WALLING WORKS	1	lot		
	Amount in Words				
IX.	ELECTRICAL WORKS	1	lot		
	Amount in Words				
X.	PAINTING WORKS	1	lot		
	Amount in Words				
XI.	PLUMBING WORKS	1	lot		
	Amount in Words				

XII.	CONSTRUCTION OF SEPTIC TANK	1	lot		
	Amount in Words				
XIII.	INSTALLATION OF DOORS AND WINDOWS	1	lot		
	Amount in Words				
XIV.	OCCUPATIONAL HEALTH AND SAFETY PROGRAM	1	lot		
	Amount in Words				

Total Bid Amount: _____

Total Bid Amount in Words: _____

Signature: _____

Printed Name: _____

Name of Company: _____

Date: _____

DETAILED ESTIMATE

AGENCY : Department of Transportation
 / CIVIL AVIATION AUTHORITY OF THE PHILIPPINES
PROJECT : Rehabilitation of Buildings at Darayday Facility
LOCATION : Darayday, Laoag City
SUBJECT : BILL OF QUANTITY/DETAILED ESTIMATE

I. HAULING

QUANTITY 1.0 LOT

A. DIRECT COST

2.	EQUIPMENT	QUANTITY	UNIT COST	AMOUNT
1	Mobile Crane	/day	/day	
2	Flat bed Truck	/day	/day	
EQUIPMENT COST				

3.	No. of Manpower	LABOR	NO. OF DAYS	UNIT COST	AMOUNT
1		Driver	/day	/day	
2		Helper	/day	/day	
LABOR COST					

TOTAL DIRECT COST

B. INDIRECT COST

1.	OCM(Overhead, Contingencies, Miscellaneous)			
2.	CONTRACTORS PROFIT			
TOTAL MARK-UP				

3.	Value Added Tax, VAT (OCM + Contractor's Profit + Direct Cost)	5%		
----	--	----	--	--

TOTAL INDIRECT COST

C. TOTAL COST

1.	DIRECT COST + INDIRECT COST			
----	-----------------------------	--	--	--

TOTAL UNIT COST

AGENCY : Department of Transportation
 / CIVIL AVIATION AUTHORITY OF THE PHILIPPINES
 PROJECT : Rehabilitation of Buildings at Darayday Facility
 LOCATION : Darayday, Laag City
 SUBJECT : BILL OF QUANTITY/DETAILED ESTIMATE

II. CONCRETE WORKS

QUANTITY 1.0 LOT

A. DIRECT COST

1. MATERIALS		QUANTITY	UNIT COST	AMOUNT
Main Building				
1	10mm dia. RSB	40	pcs	/pcs
2	40kg Cement	50	bags	/bags
3	Gravel	5	cu.mtr	/cu.mtr
4	Sand	2.5	cu.mtr	/cu.mtr
5	#16 GI Tie Wire	2	kls	/kls
6	6" Chb	110	pcs	/pcs
Building II				
7	12mm dia RSB	44	pcs	/pcs
8	10mm dia. RSB	45	pcs	/pcs
9	40kg Cement	25	bags	/bags
10	Gravel	4	cu.mtr	/cu.mtr
11	Sand	2	cu.mtr	/cu.mtr
12	#16 GI Tie Wire	5	kls	/kls
13	5" Chb	550	pcs	/pcs
Container Van				
14	12mm dia RSB	80	pcs	/pcs
15	10mm dia. RSB	64	pcs	/pcs
16	40kg Cement	30	bags	/bags
	6" Chb	100	pcs	/pcs
17	Gravel	9	cu.mtr	/cu.mtr
18	Sand	4.5	cu.mtr	/cu.mtr
19	#16 GI Tie Wire	2	kls	/kls
Comfort Room				
20	12mm dia RSB	48	pcs	/pcs
21	10mm dia. RSB	21	pcs	/pcs
22	40kg Cement	30	bags	/bags
23	5" Chb	560	pcs	/pcs
24	Gravel	7	cu.mtr	/cu.mtr
25	Sand	3.5	cu.mtr	/cu.mtr
26	#16 GI Tie Wire	7	kls	/kls
MATERIAL COST				
2. EQUIPMENT		QUANTITY	UNIT COST	AMOUNT
1	Cut-off Machine	days	days	
EQUIPMENT COST				
3. LABOR		NO. OF DAYS	UNIT COST	AMOUNT
No. of Manpower				
1	Skilled Worker	days	days	
2	Common Laborer	days	days	
LABOR COST				
TOTAL DIRECT COST				

B. INDIRECT COST

1.	DCM/ Overhead, Contingencies, Miscellaneous)			
2.	CONTRACTORS PROFIT			
TOTAL MARK-UP				
3.	Value Added Tax, VAT (DCM + Contractor's Profit + Direct Cost)	5%		
TOTAL INDIRECT COST				

C. TOTAL COST

1.	DIRECT COST + INDIRECT COST			
TOTAL UNIT COST				

AGENCY : Department of Transportation
 / CIVIL AVIATION AUTHORITY OF THE PHILIPPINES
PROJECT : Rehabilitation of Buildings at Darayday Facility
LOCATION : Darayday, Laoag City
SUBJECT : BILL OF QUANTITY/DETAILED ESTIMATE

III. TILE WORKS

QUANTITY 1.0 LOY

A. DIRECT COST

1. MATERIALS		QUANTITY	UNIT COST	AMOUNT
Main Building(130 sq.mtrs)				
1	60cmx60cm Porcelain Floor Tiles	166 pcs	/pcs	
2	30cmx60cm Matt Floor and Wall Tiles	110 pcs	/pcs	
3	Tile Grout	13 kls	/kls	
4	Tile Adhesive	13 bags	/bags	
Building II (56 sq.mtrs)				
5	60cmx60cm Porcelain Floor Tiles	110 pcs	/pcs	
6	60cmx60cm MAatt Floor Tiles	10 pcs	/pcs	
7	30cmx60cm Matt Floor and Wall Tiles	110 pcs	/pcs	
8	Tile Grout	13 kls	/kls	
9	Tile Adhesive	13 bags	/bags	
Comfort Room				
10	60cmx60cm Porcelain Floor Tiles	2 pcs		
11	30cmx60cm Matt Floor and Wall Tiles	201 pcs		
12	Tile Grout	7 kls		
13	Tile Adhesive	7 bags	/bags	
Container Van				
	0.30 Matt Floor Tiles	150 pcs	/pcs	
	Peebles	5 bags	/bags	
	Tile Adhesive	6 bags	/bags	
MATERIAL COST				

2. EQUIPMENT		QUANTITY	UNIT COST	AMOUNT
1	Angle Grinder	days	/days	
EQUIPMENT COST				

No. of Manpower	LABOR	NO. OF DAYS	UNIT COST	AMOUNT
2	Skilled Worker	days	/days	
3	Common Laborer	days	/days	
LABOR COST				

TOTAL DIRECT COST

B. INDIRECT COST

1.	OCM(Overhead, Contingencies, Miscellaneous)			
2.	CONTRACTORS PROFIT			
			TOTAL MARK-UP	

3.	Value Added Tax, VAT (OCM + Contractor's Profit + Direct Cost)	5%		
----	--	----	--	--

TOTAL INDIRECT COST

C. TOTAL COST

1.	DIRECT COST + INDIRECT COST			
TOTAL UNIT COST				

AGENCY : Department of Transportation
 / CIVIL AVIATION AUTHORITY OF THE PHILIPPINES
PROJECT : Rehabilitation of Buildings at Darayday Facility
LOCATION : Darayday, Laoag City
SUBJECT : BILL OF QUANTITY/DETAILED ESTIMATE

IV. ROOFING WORKS

QUANTITY 1.0 LOT

A. DIRECT COST

1.	MATERIALS	QUANTITY	UNIT COST	AMOUNT
Main Building				
1	2x6x1.2x6mtrs C-purlins (fascia)	4 pcs	/pcs	
2	2x2x1.2x6mtrs Tubular	18 pcs	/pcs	
3	0.5 thk Ribtype Roof Sheet, pre-painted	50 in.mtr	/in.mtr	
4	16"x0.5 thk Gutter, pre-painted	4 pcs	/pcs	
5	16"x0.5 thk End Gutter, pre-painted	5 pcs	/pcs	
6	3" GI Pipe, S40	2 pcs	/pcs	
7	1/4" MS Plate	0.3 sht	/sht	
8	4" Anchor Bolt	12 pcs	/pcs	
9	3" PVC Pipe, Orange	6 pcs	/pcs	
10	3" PVC Elbow, Orange	6 pcs	/pcs	
Building II				
11	2x6x1.2x6mtrs C-purlins(fascia)	4 pcs	/pcs	
12	2x6x1.2x6mtrs Tubular (beam and Truss)	7 pcs	/pcs	
13	2x3x1.2x6mtrs C-purlins	11 pcs	/pcs	
14	3" GI Pipe, S40	1 pcs	/pcs	
15	4" Anchor Bolt	8 pcs	/pcs	
16	0.5 thk Ribtype Roof Sheet, pre-painted	40 in.mtr	/in.mtr	
17	16"x0.5 thk Gutter, pre-painted	5 pcs	/pcs	
18	16"x0.5 thk End Gutter, pre-painted	5 pcs	/pcs	
19	3" PVC Pipe, Orange	8 pcs	/pcs	
20	3" PVC Elbow, Orange	16 pcs	/pcs	
Container Van				
21	2x6x1.2x6mtrs C-Purlins (fascia)	11 pcs	/pcs	
22	2x3x1.2x6mtrs C-Purlins (purlins)	18 pcs	/pcs	
23	2x6x1.5x6 mtrs Tubular Bar (Beam & Truss)	10 pcs	/pcs	
24	2x2x1/4x6mtrs Angle Bar (truss)	8 pcs	/pcs	
25	0.5 thk Ribtype Roof Sheet, pre-painted	70 in.mtr	/in.mtr	
26	16"x0.5 thk Gutter, pre-painted	10 pcs	/pcs	
27	16"x0.5 thk End Gutter, pre-painted	20 pcs	/pcs	
28	3" PVC Pipe, Orange	20 pcs	/pcs	
29	3" PVC Elbow, Orange	26 pcs	/pcs	
Comfort Room				
30	2x6x1.2x6mtrs C-Purlins (fascia)	1 pcs	/pcs	
31	2x3x1.2x6mtrs C-Purlins (purlins)	3 pcs	/pcs	
32	2x6x1.2x6mtrs Tubular (truss)	2 pcs	/pcs	
33	0.5 thk Ribtype Roof Sheet, pre-painted	9 in.mtr	/in.mtr	
34	16"x0.5 thk Gutter, pre-painted	2 pcs	/pcs	
35	Flashing	3 pcs	/pcs	
36	3" PVC Pipe, Orange	20 pcs	/pcs	
37	3" PVC Elbow, Orange	26 pcs	/pcs	
Pump House				
38	2x6x1.2x6mtrs C-Purlins (truss)	2 pcs	/pcs	
39	2x3x1.2x6mtrs C-Purlins (purlins)	2 pcs	/pcs	
40	0.5 thk Ribtype Roof Sheet, pre-painted	6 in.mtr		

Other Materials					
41	Solvent Cement, 200 cc	3	can		/can
42	Sealant, Clear	10	tube		/tube
43	Welding Rod	3	box		/box
44	Cutting Disk	5	pcs		/pcs
45	Texcrew	500	pcs		/pcs
46	Epoxy Primer Gray	3	gal		/gal
47	QDE Paint, Black	3	gal		/gal
48	Assorted size Paint Brush	5	pcs		/pcs
MATERIAL COST					

2. EQUIPMENT		QUANTITY	UNIT COST	AMOUNT
1	Cut-off machine	day	/day	
2	Welding Machine	day	/day	
EQUIPMENT COST				

3. No. of Manpower		LABOR	NO. OF DAYS	UNIT COST	AMOUNT
1		Skilled Worker	days	/days	
2		Common laborer	days	/days	
LABOR COST					

TOTAL DIRECT COST

B. INDIRECT COST

1.	OCM(Overhead, Contingencies, Miscellaneous)			
2.	CONTRACTORS PROFIT			
			TOTAL MARK-UP	
3.	Value Added Tax, VAT (OCM + Contractor's Profit + Direct Cost)	5%		
TOTAL INDIRECT COST				

C. TOTAL COST

1.	DIRECT COST + INDIRECT COST	
TOTAL UNIT COST		

AGENCY : Department of Transportation
 / CIVIL AVIATION AUTHORITY OF THE PHILIPPINES
 PROJECT : Rehabilitation of Buildings at Darayday Facility
 LOCATION : Darayday, Laoag City
 SUBJECT : BILL OF QUANTITY/DETAILED ESTIMATE

V. CEILING WORKS

QUANTITY 1.0 LOT

A. DIRECT COST

1. MATERIALS		QUANTITY	UNIT COST	AMOUNT
Main Building				
1	3.5mmx4'x8' Fiber Cement Board	21 pcs	/pcs	
2	2.95mx250cmx8mm PVC Ceiling Panel	40 pcs	/pcs	
3	Metal Furring	90 pcs	/pcs	
4	Wall Angle	48 pcs	/pcs	
5	C-channel	10 pcs	/pcs	
Building II				
6	3.5mmx4'x8' Fiber Cement Board	13 pcs	/pcs	
7	2.95mx250cmx8mm PVC Ceiling Panel	30 pcs	/pcs	
8	Metal Furring	68 pcs	/pcs	
9	Wall Angle	30 pcs	/pcs	
10	C-channel	6 pcs	/pcs	
Container Van				
11	2.95mx250cmx8mm PVC Ceiling Panel	100 pcs	/pcs	
12	Metal Furring	42 pcs	/pcs	
13	Wall Angle	75 pcs	/pcs	
14	C-channel	20 pcs	/pcs	
Comfort Room				
15	3.5mmx4'x8' Fiber Cement Board	4 pcs	/pcs	
16	Metal Furring	15 pcs	/pcs	
17	Wall Angle	4 pcs	/pcs	
18	C-channel	4 pcs	/pcs	
Other Materials				
19	Putty	3 gal	/gal	
20	5/32 x 3/4 Blind Rivet	5 box	/box	
21	5/32 Drill Bit	10 pcs	/pcs	
22	Sand Paper	10 shts	/shts	
23	Acrylic Latex Paint, Primer	10 gal	/gal	
24	Flat Latex	20 gal	/gal	
MATERIAL COST				

2. EQUIPMENT		QUANTITY	UNIT COST	AMOUNT
1	Electric Drill	days	/days	
EQUIPMENT COST				

No. of Manpower	LABOR	NO. OF DAYS	UNIT COST	AMOUNT
1	Skilled Worker	days	650.00 /days	
2	Common Laborer	days	400.00 /days	
LABOR COST				

TOTAL DIRECT COST

B. INDIRECT COST

1.	DCM (Overhead, Contingencies, Miscellaneous)			
2.	CONTRACTORS PROFIT			
			TOTAL MARK-UP	
3.	Value Added Tax, VAT (DCM + Contractor's Profit + Direct Cost)	5%		

TOTAL INDIRECT COST

C. TOTAL COST

1.	DIRECT COST + INDIRECT COST			
TOTAL UNIT COST				

AGENCY : Department of Transportation
 / CIVIL AVIATION AUTHORITY OF THE PHILIPPINES
PROJECT : Rehabilitation of Buildings at Darayday Facility
LOCATION : Darayday, Laoag City
SUBJECT : BILL OF QUANTITY/DETAILED ESTIMATE

VI. STEEL WORKS

QUANTITY 1.0 LOT

A. DIRECT COST

1. MATERIALS		QUANTITY	UNIT COST	AMOUNT
Building II				
1	2x3x1.5x6mtrs Tubular	2 pcs	/pcs	
2	1x2x1.5x6mtrs Tubular	3 pcs	/pcs	
3	Welding Rod	0.5 box	/box	
4	Cutting Disk	1 pcs	/pcs	
Container Van				
5	2x3x1.5x6 mtrs (Railings)	3 pcs	/pcs	
MATERIAL COST				

2. EQUIPMENT		QUANTITY	UNIT COST	AMOUNT
1	Welding Machine	day	/day	
2	Cut-off Machine	day	/day	
EQUIPMENT COST				

3. LABOR		NO. OF DAYS	UNIT COST	AMOUNT
No. of Manpower				
1	Skilled Worker	days	/days	
LABOR COST				

TOTAL DIRECT COST

B. INDIRECT COST

1.	OCM(Overhead, Contingencies, Miscellaneous)			
2.	CONTRACTORS PROFIT			
			TOTAL MARK-UP	
3.	Value Added Tax, VAT (OCM + Contractor's Profit + Direct Cost)	5%		

TOTAL INDIRECT COST

C. TOTAL COST

1.	DIRECT COST + INDIRECT COST			
----	------------------------------------	--	--	--

TOTAL UNIT COST

AGENCY : Department of Transportation
 / CIVIL AVIATION AUTHORITY OF THE PHILIPPINES
PROJECT : Rehabilitation of Buildings at Darayday Facility
LOCATION : Darayday, Laoag City
SUBJECT : BILL OF QUANTITY/DETAILED ESTIMATE

VII. Flooring Works

QUANTITY 1.0 LOT

A. DIRECT COST

1. MATERIALS		QUANTITY		UNIT COST		AMOUNT
Container Van						
1	2x2x1.5x6mtrs Tubular	13	pcs		/pcs	
2	3/4" Marine Plywood	10	shts		/shts	
3	15cmx60cm Vinyl Floor Tiles	320	pcs		/pcs	
4	Flooring Adhesive (for vinyl)	5	gal		/gal	
5	3" Metal Screw	300	pcs		/pcs	
MATERIAL COST						
2. EQUIPMENT		QUANTITY		UNIT COST		AMOUNT
1	Cut-off Machine		days		/days	
EQUIPMENT COST						
3. LABOR		NO. OF DAYS		UNIT COST		AMOUNT
No. of Manpower						
1	Skilled Worker		days		/days	
LABOR COST						
TOTAL DIRECT COST						

B. INDIRECT COST

1.	OCM (Overhead, Contingencies, Miscellaneous)			
2.	CONTRACTORS PROFIT			
				TOTAL MARK-UP
3.	Value Added Tax, VAT (OCM + Contractor's Profit + Direct Cost)	5%		
TOTAL INDIRECT COST				

C. TOTAL COST

1.	DIRECT COST + INDIRECT COST	
TOTAL UNIT COST		

AGENCY : Department of Transportation
 / CIVIL AVIATION AUTHORITY OF THE PHILIPPINES
 PROJECT : Rehabilitation of Buildings at Darayday Facility
 LOCATION : Darayday, Laoag City
 SUBJECT : BILL OF QUANTITY/DETAILED ESTIMATE

VIII. Walling Works

QUANTITY 1.0 LOT

A. DIRECT COST

1. MATERIALS		QUANTITY	UNIT COST	AMOUNT
Container Van				
1	2x4 Metal Stud	112 pcs	/pcs	
2	4.5mmx4'x8' Fiber Cement Board	28 shts	/shts	
3	5/32 x 3/4 Blind Rivet	5 box	/box	
4	5/32 Drill Bit	5 pcs	/pcs	
MATERIAL COST				
2. EQUIPMENT		QUANTITY	UNIT COST	AMOUNT
1	Electric Drill	lot	/lot	
EQUIPMENT COST				
No. of Manpower	LABOR	NO. OF DAYS	UNIT COST	AMOUNT
1	Skilled Worker	days	/days	
LABOR COST				
TOTAL DIRECT COST				

B. INDIRECT COST

1.	OCM(Overhead, Contingencies, Miscellaneous)			
2.	CONTRACTORS PROFIT			
			TOTAL MARK-UP	
3.	Value Added Tax, VAT (OCM + Contractor's Profit + Direct Cost)	5%		
TOTAL INDIRECT COST				

C. TOTAL COST

1.	DIRECT COST + INDIRECT COST			
TOTAL UNIT COST				

AGENCY : Department of Transportation
 / CIVIL AVIATION AUTHORITY OF THE PHILIPPINES
PROJECT : Rehabilitation of of Buildings at Darayday Facility
LOCATION : Darayday, Laoag City
SUBJECT : BILL OF QUANTITY/DETAILED ESTIMATE

IX. Electrical Works

QUANTITY 1.0 LOT

A. DIRECT COST

1. MATERIALS		QUANTITY	UNIT COST	AMOUNT
1	Receptacle	16 pcs	/pcs	
2	11 Watts LED Bulb E27	16 pcs	/pcs	
3	1 Gang Switch	5 sets	/sets	
4	2 Gang Switch	6 sets	/sets	
5	3 Gang Switch	3 sets	/sets	
6	3 Way Switch	2 sets	/sets	
6	2.0mm ² THHN Wire	1 box	/box	
7	2 Gang CO	15 sets	/sets	
8	ACU Outlet	4 sets	/sets	
9	3.5 mm ² THHN Wire	1 box	/box	
10	5.5 mm ² THHN Wire	1 box	/box	
11	8-Holes 2P Bolt on with CM	1 pcs	/pcs	
12	10-Holes 2P Bolt on with CM	1 pcs	/pcs	
13	15AT 2P Bolt on CB	4 pcs	/pcs	
14	20AT 2P Bolt on CB	5 pcs	/pcs	
15	30AT 2P Bolt on CB	6 pcs	/pcs	
16	70AT 2P Bolt on CB	2 pcs	/pcs	
17	100AT 2P Bolt on CB	2 pcs	/pcs	
18	175AT 2P Bolt on CB	2 pcs	/pcs	
19	22mm ² THHN Wire	40 mtrs	/mtrs	
20	30mm ² THHN Wire	50 mtrs	/mtrs	
21	20mmØ PVC Conduits	67 pcs	/pcs	
22	32mmØ PVC Conduits	16 pcs	/pcs	
23	Solvent Cement, 400 cc	1 can	/can	
24	Electrical Tape Big	5 pcs	/pcs	

MATERIAL COST

2. EQUIPMENT		QUANTITY	UNIT COST	AMOUNT
1	Minor Tools (10% of Labor Cost)	lot	/lot	

EQUIPMENT COST

No. of Manpower	LABOR	NO. OF DAYS	UNIT COST	AMOUNT
1	Electrician	days	/days	
2	Helper	days	/days	

LABOR COST

TOTAL DIRECT COST

B. INDIRECT COST

1.	OCM(Overhead, Contingencies, Miscellaneous)			
2.	CONTRACTORS PROFIT			
			TOTAL MARK-UP	
3.	Value Added Tax, VAT (OCM + Contractor's Profit + Direct Cost)	5%		

TOTAL INDIRECT COST

C. TOTAL COST

1.	DIRECT COST + INDIRECT COST			
----	-----------------------------	--	--	--

TOTAL UNIT COST

AGENCY : Department of Transportation
 / CIVIL AVIATION AUTHORITY OF THE PHILIPPINES
PROJECT : Rehabilitation of of Buildings at Darayday Facility
LOCATION : Darayday, Laoag City
SUBJECT : BILL OF QUANTITY/DETAILED ESTIMATE

X. Painting Works

QUANTITY 1.0 LOT

A. DIRECT COST

1. MATERIALS		QUANTITY	UNIT COST	AMOUNT
Building 2				
1	Acrylic Latex Paint, Primer	5 gal	/gal	
2	Acrylic Latex Paint, Semi Gloss	7 pcs	/pcs	
3	Sand Paper	10 shts	/shts	
4	Paint Roller	2 sets	/sets	
Container Van				
5	Acrylic Latex Paint (inside wall)	6 gals	/gals	
6	QDE Paint, White	7 gal	/gal	
7	Paint Brush	3 pcs	/pcs	
MATERIAL COST				
2. EQUIPMENT		QUANTITY	UNIT COST	AMOUNT
1	Minor Tools (10% of Labor Cost)	lot	/lot	
EQUIPMENT COST				
3. LABOR		NO. OF DAYS	UNIT COST	AMOUNT
	No. of Manpower			
1	Skilled Worker	days	/days	
LABOR COST				
TOTAL DIRECT COST				

B. INDIRECT COST

1.	OCM(Overhead, Contingencies, Miscellaneous)			
2.	CONTRACTORS PROFIT			
			TOTAL MARK-UP	
3.	Value Added Tax, VAT (OCM + Contractor's Profit + Direct Cost)	5%		
TOTAL INDIRECT COST				

C. TOTAL COST

1.	DIRECT COST + INDIRECT COST	
TOTAL UNIT COST		

AGENCY : Department of Transportation
 / CIVIL AVIATION AUTHORITY OF THE PHILIPPINES
PROJECT : Rehabilitation of of Buildings at Darayday Facility
LOCATION : Darayday, Laoag City
SUBJECT : BILL OF QUANTITY/DETAILED ESTIMATE

XI. Plumbing Works

QUANTITY 1.0 LOT

A. DIRECT COST

1. MATERIALS		QUANTITY	UNIT COST	AMOUNT
1	3/4" PPR PN20	8 pcs	/pcs	
2	3/4" TEE PPR Plain	7 pcs	/pcs	
3	3/4" x 1/2" Coupling Reducer, PPR	10 pcs	/pcs	
4	1/2" PPR PN20	2 pcs	/pcs	
5	Kitchen Sink	1 set	/set	
6	Lavatory (counter top)	1 set	/set	
7	Lavatory with stand	3 sets	/sets	
8	Water Closet (dual flush)	3 set	/set	
9	1/2" Elbow w/ Female Thread	7 pcs	/pcs	
10	Dual Angle Valve, Stainless Steel	3 pcs	/pcs	
11	Single Angle Valve, Stainless Steel	4 pcs	/pcs	
12	3/4 Plain Elbow	4 pcs	/pcs	
13	Bidet (Hand Spray)	3 pcs	/pcs	
14	Faucet	7 pcs	/pcs	
15	Teflon	4 pcs	/pcs	
16	4" PVC Pipe, Orange	7 pcs	/pcs	
17	2" PVC Pipe, Orange	8 pcs	/pcs	
18	4" P-trap	3 pcs	/pcs	
19	2" P-trap	5 pcs	/pcs	
20	4" Elbow, Orange	7 pcs	/pcs	
21	4" Wye, Orange	4 pcs	/pcs	
22	2" Wye, Orange	1 pcs	/pcs	
23	2" Elbow, Orange	8 pcs	/pcs	
24	82 Gal Pressure Tank	1 unit	/unit	
25	1.5 Hp, Electric Water Pump	1 unit	/unit	
MATERIAL COST				

2. EQUIPMENT		QUANTITY	UNIT COST	AMOUNT
1	Minor Tools (10% of Labor Cost)	lot	/lot	
EQUIPMENT COST				

No. of Manpower	LABOR	NO. OF DAYS	UNIT COST	AMOUNT
1	Skilled Worker	days	/days	
LABOR COST				

TOTAL DIRECT COST

B. INDIRECT COST

1.	OCM (Overhead, Contingencies, Miscellaneous)			
2.	CONTRACTORS PROFIT		TOTAL MARK-UP	
3.	Value Added Tax, VAT (OCM + Contractor's Profit + Direct Cost)	5%		

TOTAL INDIRECT COST

C. TOTAL COST

1.	DIRECT COST + INDIRECT COST			
----	-----------------------------	--	--	--

TOTAL UNIT COST

AGENCY : Department of Transportation
 / CIVIL AVIATION AUTHORITY OF THE PHILIPPINES
PROJECT : Rehabilitation of Buildings at Darayday Facility
LOCATION : Darayday, Laoag City
SUBJECT : BILL OF QUANTITY/DETAILED ESTIMATE

XII. Construction of Septic Tank

QUANTITY 1.0 LOT

A. DIRECT COST

1. MATERIALS		QUANTITY		UNIT COST		AMOUNT
1	5" Chb	240	pcs		/pcs	
2	10mm x 6m RSb	15	pcs		/pcs	
3	Cement	10	bags		/bags	
4	Gravel	2	cu.mtr		/cu.mtr	
5	Sand	1	cu.mtr		/cu.mtr	
MATERIAL COST						

2. No. of Manpower		LABOR	NO. OF DAYS	UNIT COST	AMOUNT
1		Skilled Worker	days	/days	
2		Common Laborer	days	/days	
LABOR COST					

TOTAL DIRECT COST

B. INDIRECT COST

1.	OCM (Overhead, Contingencies, Miscellaneous)			
2.	CONTRACTORS PROFIT			
			TOTAL MARK-UP	
3.	Value Added Tax, VAT (OCM + Contractor's Profit + Direct Cost)	5%		
TOTAL INDIRECT COST				

C. TOTAL COST

1.	DIRECT COST + INDIRECT COST	
----	-----------------------------	--

TOTAL UNIT COST

AGENCY : Department of Transportation
 / CIVIL AVIATION AUTHORITY OF THE PHILIPPINES
PROJECT : Rehabilitation of Buildings at Darayday Facility
LOCATION : Darayday, Laoag City
SUBJECT : BILL OF QUANTITY/DETAILED ESTIMATE

XIII. INSTALLATION OF DOOR AND WINDOWS

QUANTITY 1.0 LOT

A. DIRECT COST

1.	MATERIALS	QUANTITY	UNIT COST	AMOUNT
Building II				
1	One-way Mirror Glass Awning type Window, white Frame	8.5 sq.mtr	/sq.mtr	
2	Panel Door 0.90x2.1 mtrs width	2 set	/set	
3	Panel Door 0.80x2.1 mtrs width	2 set	/set	
4	PVC Door .60 mtrs width	1 set	/set	
Container Van				
5	One-way Mirror Glass Awning type Window, white Frame	8.7 sq.mtr	/sq.mtr	
6	Panel Door 0.90x2.1 mtrs width	2 set	/set	
Comfort Room				
7	One-way Mirror Glass Awning type Window, white Frame	1 sq.mtr	/sq.mtr	
8	PVC Door .60 mtrs width	2 set	/set	
MATERIAL COST				

2.	No. of Manpower	LABOR	NO. OF DAYS	UNIT COST	AMOUNT
1		Skilled Worker	days	/days	
LABOR COST					

TOTAL DIRECT COST

B. INDIRECT COST

1.	OCM(Overhead, Contingencies, Miscellaneous)			
2.	CONTRACTORS PROFIT			
			TOTAL MARK-UP	
3.	Value Added Tax, VAT (OCM + Contractor's Profit + Direct Cost)	5%		
TOTAL INDIRECT COST				

C. TOTAL COST

1.	DIRECT COST + INDIRECT COST	
TOTAL UNIT COST		

AGENCY : Department of Transportation
 / CIVIL AVIATION AUTHORITY OF THE PHILIPPINES
PROJECT : Rehabilitation of Buildings at Darayday Facility
LOCATION : Darayday Laoag City
SUBJECT : BILL OF QUANTITY/DETAILED ESTIMATE

XIV. OCCUPATIONAL HEATH AND SAFETY PROGRAM

QUANTITY 1.0 LOT

A. DIRECT COST

EQUIPMENT		QUANTITY	UNIT COST	AMOUNT
1	Reflectorized Vest, Safety Shoes, Hard Hat	sets	/sets	
EQUIPMENT COST				

TOTAL DIRECT COST

B. INDIRECT COST

1.	Value Added Tax, VAT (OCM + Contractor's Profit + Direct Cost)	5%		
----	--	----	--	--

TOTAL INDIRECT COST

C. TOTAL COST

1.	DIRECT COST + INDIRECT COST			
----	-----------------------------	--	--	--

TOTAL UNIT COST

Omnibus Sworn Statement (Revised)
[shall be submitted with the Bid]

REPUBLIC OF THE PHILIPPINES)
CITY/MUNICIPALITY OF _____) S.S.

AFFIDAVIT

I, [Name of Affiant], of legal age, [Civil Status], [Nationality], and residing at [Address of Affiant], after having been duly sworn in accordance with law, do hereby depose and state that:

1. *[Select one, delete the other:]*

[If a sole proprietorship:] I am the sole proprietor or authorized representative of [Name of Bidder] with office address at [address of Bidder];

[If a partnership, corporation, cooperative, or joint venture:] I am the duly authorized and designated representative of [Name of Bidder] with office address at [address of Bidder];

2. *[Select one, delete the other:]*

[If a sole proprietorship:] As the owner and sole proprietor, or authorized representative of [Name of Bidder], I have full power and authority to do, execute and perform any and all acts necessary to participate, submit the bid, and to sign and execute the ensuing contract for [Name of the Project] of the [Name of the Procuring Entity], as shown in the attached duly notarized Special Power of Attorney;

[If a partnership, corporation, cooperative, or joint venture:] I am granted full power and authority to do, execute and perform any and all acts necessary to participate, submit the bid, and to sign and execute the ensuing contract for [Name of the Project] of the [Name of the Procuring Entity], as shown in the attached [state title of attached document showing proof of authorization (e.g., duly notarized Secretary's Certificate, Board/Partnership Resolution, or Special Power of Attorney, whichever is applicable)];

3. [Name of Bidder] is not "blacklisted" or barred from bidding by the Government of the Philippines or any of its agencies, offices, corporations, or Local Government Units, foreign government/foreign or international financing institution whose blacklisting rules have been recognized by the Government Procurement Policy Board, **by itself or by relation, membership, association, affiliation, or controlling interest with another blacklisted person or entity as defined and provided for in the Uniform Guidelines on Blacklisting;**

4. Each of the documents submitted in satisfaction of the bidding requirements is an authentic copy of the original, complete, and all statements and information provided therein are true and correct;

5. [Name of Bidder] is authorizing the Head of the Procuring Entity or its duly authorized representative(s) to verify all the documents submitted;

6. *[Select one, delete the rest:]*

[If a sole proprietorship:] The owner or sole proprietor is not related to the Head of the Procuring Entity, members of the Bids and Awards Committee (BAC), the Technical Working Group, and the BAC Secretariat, the head of the Project Management Office or the end-user unit, and the project consultants by consanguinity or affinity up to the third civil degree;

[If a partnership or cooperative:] None of the officers and members of *[Name of Bidder]* is related to the Head of the Procuring Entity, members of the Bids and Awards Committee (BAC), the Technical Working Group, and the BAC Secretariat, the head of the Project Management Office or the end-user unit, and the project consultants by consanguinity or affinity up to the third civil degree;

[If a corporation or joint venture:] None of the officers, directors, and controlling stockholders of *[Name of Bidder]* is related to the Head of the Procuring Entity, members of the Bids and Awards Committee (BAC), the Technical Working Group, and the BAC Secretariat, the head of the Project Management Office or the end-user unit, and the project consultants by consanguinity or affinity up to the third civil degree;

7. *[Name of Bidder]* complies with existing labor laws and standards; and
8. *[Name of Bidder]* is aware of and has undertaken the responsibilities as a Bidder in compliance with the Philippine Bidding Documents, which includes:
 - a. Carefully examining all of the Bidding Documents;
 - b. Acknowledging all conditions, local or otherwise, affecting the implementation of the Contract;
 - c. Making an estimate of the facilities available and needed for the contract to be bid, if any; and
 - d. Inquiring or securing Supplemental/Bid Bulletin(s) issued for the *[Name of the Project]*.
9. *[Name of Bidder]* did not give or pay directly or indirectly, any commission, amount, fee, or any form of consideration, pecuniary or otherwise, to any person or official, personnel or representative of the government in relation to any procurement project or activity.
10. **In case advance payment was made or given, failure to perform or deliver any of the obligations and undertakings in the contract shall be sufficient grounds to constitute criminal liability for Swindling (Estafa) or the commission of fraud with unfaithfulness or abuse of confidence through misappropriating or converting any payment received by a person or entity under an obligation involving the duty to deliver certain goods or services, to the prejudice of the public and the government of the Philippines pursuant to Article 315 of Act No. 3815 s. 1930, as amended, or the Revised Penal Code.**

IN WITNESS WHEREOF, I have hereunto set my hand this ___ day of ___, 20__ at _____, Philippines.

[Insert NAME OF BIDDER OR ITS AUTHORIZED REPRESENTATIVE]

[Insert signatory's legal capacity]

Affiant

[Jurat]

[Format shall be based on the latest Rules on Notarial Practice]

Bid Form for the Procurement of Infrastructure Projects *[shall be submitted with the Bid]*

BID FORM

Date : _____
Project Identification No. : _____

To: *[name and address of Procuring Entity]*

Having examined the Philippine Bidding Documents (PBDs) including the Supplemental or Bid Bulletin Numbers *[insert numbers]*, the receipt of which is hereby duly acknowledged, we, the undersigned, declare that:

- a. We have no reservation to the PBDs, including the Supplemental or Bid Bulletins, for the Procurement Project: *[insert name of contract]*;
- b. We offer to execute the Works for this Contract in accordance with the PBDs;
- c. The total price of our Bid in words and figures, excluding any discounts offered below is: *[insert information]*;
- d. The discounts offered and the methodology for their application are: *[insert information]*;
- e. The total bid price includes the cost of all taxes, such as, but not limited to: *[specify the applicable taxes, e.g. (i) value added tax (VAT), (ii) income tax, (iii) local taxes, and (iv) other fiscal levies and duties]*, which are itemized herein and reflected in the detailed estimates,
- f. Our Bid shall be valid within the a period stated in the PBDs, and it shall remain binding upon us at any time before the expiration of that period;
- g. If our Bid is accepted, we commit to obtain a Performance Security in the amount of *[insert percentage amount]* percent of the Contract Price for the due performance of the Contract, or a Performance Securing Declaration in lieu of the the allowable forms of Performance Security, subject to the terms and conditions of issued GPPB guidelines¹ for this purpose;
- h. We are not participating, as Bidders, in more than one Bid in this bidding process, other than alternative offers in accordance with the Bidding Documents;
- i. We understand that this Bid, together with your written acceptance thereof included in your notification of award, shall constitute a binding contract between us, until a formal Contract is prepared and executed; and
- j. We understand that you are not bound to accept the Lowest Calculated Bid or any

¹ currently based on GPPB Resolution No. 09-2020

other Bid that you may receive.

- k. We likewise certify/confirm that the undersigned, is the duly authorized representative of the bidder, and granted full power and authority to do, execute and perform any and all acts necessary to participate, submit the bid, and to sign and execute the ensuing contract for the [Name of Project] of the [Name of the Procuring Entity].
- l. We acknowledge that failure to sign each and every page of this Bid Form, including the Bill of Quantities, shall be a ground for the rejection of our bid.

Name: _____

Legal Capacity: _____

Signature: _____

Duly authorized to sign the Bid for and behalf of: _____

Date: _____

Section IX. Checklist of Technical and Financial Documents

Notes on the Checklist of Technical and Financial Documents

The prescribed documents in the checklist are mandatory to be submitted in the Bid, but shall be subject to the following:

- a. GPPB Resolution No. 09-2020 on the efficient procurement measures during a State of Calamity or other similar issuances that shall allow the use of alternate documents in lieu of the mandated requirements; or
- b. any subsequent GPPB issuances adjusting the documentary requirements after the effectivity of the adoption of the PBDs.

The BAC shall be checking the submitted documents of each Bidder against this checklist to ascertain if they are all present, using a non-discretionary “pass/fail” criterion pursuant to Section 30 of the 2016 revised IRR of RA No. 9184.

Checklist of Technical and Financial Documents

I. TECHNICAL COMPONENT ENVELOPE

Class “A” Documents

Legal Documents

- (a) Valid PhilGEPS Registration Certificate (Platinum Membership) (all pages);
or
- (b) Registration certificate from Securities and Exchange Commission (SEC), Department of Trade and Industry (DTI) for sole proprietorship, or Cooperative Development Authority (CDA) for cooperatives or its equivalent document;
and
- (c) Mayor’s or Business permit issued by the city or municipality where the principal place of business of the prospective bidder is located, or the equivalent document for Exclusive Economic Zones or Areas;
and
- (e) Tax clearance per E.O. No. 398, s. 2005, as finally reviewed and approved by the Bureau of Internal Revenue (BIR).

Technical Documents

- (f) Statement of the prospective bidder of all its ongoing government and private contracts, including contracts awarded but not yet started, if any, whether similar or not similar in nature and complexity to the contract to be bid; **and**
- (g) Statement of the bidder’s Single Largest Completed Contract (SLCC) similar to the contract to be bid, except under conditions provided under the rules; **and**
- (h) Philippine Contractors Accreditation Board (PCAB) License;
or
Special PCAB License in case of Joint Ventures;
and registration for the type and cost of the contract to be bid; **and**
- (i) Original copy of Bid Security. If in the form of a Surety Bond, submit also a certification issued by the Insurance Commission;
or
Original copy of Notarized Bid Securing Declaration; **and**
- (j) Project Requirements, which shall include the following:
 - a. Organizational chart for the contract to be bid;
 - b. List of contractor’s key personnel (*e.g.*, Project Manager, Project Engineers, Materials Engineers, and Foremen), to be assigned to the contract to be bid, with their complete qualification and experience data;
 - c. List of contractor’s major equipment units, which are owned, leased, and/or under purchase agreements, supported by proof of ownership or certification of availability of equipment from the equipment lessor/vendor for the duration of the project, as the case may be; **and**
- (k) Original duly signed Omnibus Sworn Statement (OSS);

and if applicable, Original Notarized Secretary's Certificate in case of a corporation, partnership, or cooperative; or Original Special Power of Attorney of all members of the joint venture giving full power and authority to its officer to sign the OSS and do acts to represent the Bidder.

Financial Documents

- (l) The prospective bidder's audited financial statements, showing, among others, the prospective bidder's total and current assets and liabilities, stamped "received" by the BIR or its duly accredited and authorized institutions, for the preceding calendar year which should not be earlier than two (2) years from the date of bid submission; **and**
- (m) The prospective bidder's computation of Net Financial Contracting Capacity (NFCC).

Class "B" Documents

- (n) If applicable, duly signed joint venture agreement (JVA) in accordance with RA No. 4566 and its IRR in case the joint venture is already in existence;
or
duly notarized statements from all the potential joint venture partners stating that they will enter into and abide by the provisions of the JVA in the instance that the bid is successful.

II. FINANCIAL COMPONENT ENVELOPE

- (o) Original of duly signed and accomplished Financial Bid Form; **and**

Other documentary requirements under RA No. 9184

- (p) Original of duly signed Bid Prices in the Bill of Quantities; **and**
- (q) Duly accomplished Detailed Estimates Form, including a summary sheet indicating the unit prices of construction materials, labor rates, and equipment rentals used in coming up with the Bid; **and**
- (r) Cash Flow by Quarter.

Republic of the Philippines



Government Procurement Policy Board